

Quick Start Guide

Compact Vector Drive

EVO 6800 Series



Table of Contents

Chapter 1 Safety.....	1
1.1 General Safety.....	1
1.1.1 Usage.....	1
1.1.2 Receiving	1
1.1.3 Installation.....	1
1.1.4 Wiring.....	2
1.1.5 Operation	2
1.1.6 Maintenance	3
1.2 Warning Label	4
1.3 AC Drive Application Precautions.....	4
1.3.1 AC Drive Selection	4
1.3.2 Settings	5
1.3.3 General Handling.....	5
1.4 Warranty.....	6
1.4.1 Warranty Period	6
1.4.2 Warranty Restrictions	6
Chapter 2 Product	7
2.1 Component Names.....	7
2.1.1 IP20 Enclosure	7
2.1.2 NEMA Type 1 Enclosure	10
2.2 Receiving Checklist	13
2.3 Nameplate	13

2.4 Model Number Definition	14
2.5 Power Ratings	14
2.6 Common Specifications	15
2.7 Product Dimensions	17
2.8 Options	24
Chapter 3 Drive Installation.....	26
3.1 Installation Environment	26
3.2 Installation Direction and Spacing	27
3.2.1 Installation Direction.....	27
3.2.2 Installation Spacing.....	27
3.3 Keypad and Terminal Cover Installation.....	29
3.4 Wiring Protection	29
3.4.1 Drive and Input Cable Protection for Short-Circuit Situations.....	30
3.4.2 Motors and Output Cable Protection for Short-Circuit Situations	30
3.5 Keypad Remote Usage	31
3.5.1 Remote Operation.....	31
3.5.2 External/Face-Mount.....	33
Chapter 4 Wiring.....	36
4.1 Wiring Safety	36
4.2 Main Circuit.....	37
4.2.1 Main Circuit Terminal.....	38
4.2.2 Main Circuit Wiring	39
4.2.3 Main Circuit Cable Size and Tightening Torque	42
4.3 Control Circuit	44
4.3.1 Control Circuit Terminals	45
4.3.2 Control Circuit Cable Size and Tightening Torque.....	52

4.3.4 Ferrule-Type Terminals.....	53
4.4 I/O Connections.....	54
4.4.1 NPN and PNP Mode Selection	54
4.4.3 Terminal AM Voltage/Current Output Selection.....	57
4.4.4 RS-485 Communication Termination ON / OFF Switch.....	58
4.5 Connection to PC.....	58
4.6 Wiring Checklist.....	59
Chapter 5 Keypad and Parameters	60
5.1 Keypad	60
5.1.1 Keys and Displays	60
5.1.2 Keypad Display.....	63
5.1.3 Keypad Programming.....	65
5.2 Parameter List	66
6.1 Alarm and Fault Displays.	110
6.2 Fault Detection.....	115
6.4 Auto-Tuning Fault Detection	127
Chapter 7 Communications	128
7.1 Modbus Communication Specifications	128
7.2 Connecting to Controller/PLC/HMI.....	128
7.2.1 Communication Cable Connection	128
7.3 Message Format	129
7.3.1 Slave Station Address	129
7.3.2 Function Code	129
7.4 Modbus Data.....	130

Chapter 1 | Safety

1.1 General Safety

Safety Information:

Warning: Indicates highly dangerous consequences such as fire, serious injury and death when failing to comply with the instructions.

Caution: Indicates dangerous consequences such as moderate injury and equipment damage when failing to comply with the instructions.

1.1.1 Usage

Danger
<ol style="list-style-type: none">1. The drive is used to control the speed of 3 phase synchronous and asynchronous motors, which must not be used for single phase or other purposes. Failure to comply could cause drive damage or serious injury by fire.2. The drive must not be used in any medical equipment in which human life may involve.3. The drive is manufactured according to strict quality control standard. However, bypass the safety protection in case the drive failure causes death or serious injury.

1.1.2 Receiving

Warning
<ol style="list-style-type: none">1. Do not install damaged drive or any drive without complete components inside. Failure to comply could result in accident.

1.1.3 Installation

Warning
<ol style="list-style-type: none">1. Carry the drive by the bottom as carrying by the front cover may cause injury and damage from the main body of the drive falling.2. Attach the drive to metal or other nonflammable materials. Keep away from heat and flammable items.3. A control panel must have cooling fans, air vents and room for ventilation when the drive is installed inside.

1.1.4 Wiring

Danger
<ol style="list-style-type: none">1. Allow only qualified electrical engineers to install the drive. Failure to comply could cause electrical shocks to personnel or damage to the drive.2. Ensure the power supply is off when connecting. Failure to comply could cause electrical shocks.3. Ensure the ground terminal PE is properly wired. Failure to comply could cause electrical shocks from the drive cover. Therefore ground the drive and motor for personnel safety.4. Do not touch the main circuit terminal. Keep the main circuit off drive cover to avoid electrical shocks.5. The terminal for braking resistor is B1 and B2. Do not connect it to any other terminals. Failure to comply could cause a fire.
Warning
<ol style="list-style-type: none">1. Do not connect three-phase power supply to terminals U, V and W. Failure to comply could damage the drive.2. An output reactor is recommended when the cable connecting between the drive and motor is over 100 meters. Failure to comply could result in drive damage with overcurrent caused by over-distributed capacitance.3. Never connect the output terminals to capacitors or unapproved LC/RC filters. Failure to comply could damage the drive components.4. Separate the drive main circuit cables and control circuit cables. Failure to comply could cause interference to the control signals5. Ensure the phase of power supply and rated voltage match the label on the drive. Failure to comply could drive damage.

1.1.5 Operation

Danger
<ol style="list-style-type: none">1. Connect the power after completion of wiring and closing the front cover. Opening the front cover when the power is on could cause an electrical shock.2. Keep other personnel off the equipment when setting the drive fault restart and momentary power loss restart functions. Failure to comply could cause damage to the personnel and equipment.3. Once the drive is powered, the terminals are live even when drive is not in operation. Touching the terminals could cause electrical shocks.

4. Cancel run command before resetting the alarm and fault. Failure to comply could cause physical injury.
Warning
1. Do not start or stop the drive by connection or disconnection the power supply. Failure to comply could cause drive damage.
2. Ensure the motor and equipment are in proper use before operation. Failure to; comply could damage the equipment.
3. The temperature of the braking resistor and heatsink could be very high during operation. Do not touch it or it could result in scald.
4. For lift applications, please install mechanical brakes.
5. Adjust a few parameters only if necessary as the defaults are optimum settings for most of applications. Editing parameters indiscriminately could cause equipment abnormal operation.
6. Interlock the electricity supply with AC drive supply when both are available to a motor.

1.1.6 Maintenance

Danger
1. Do not touch the main circuit of the drive when power is on. Failure to comply could cause electrical shocks.
2. Disconnect the power supply before opening the front cover of the drive.
3. Maintain the drive only when the CHARGE indicator light is off or 5 minutes after turning off power supply, so as to avoid charged capacitors causing physical injury.
4. Allow only qualified electric engineers and electrician to maintain, repair and replace the AC drive modules.
Warning
1. The release of breaker on the AC drive primary side could be caused by incorrect wiring, short circuit and damaged drive components. Investigate and remove the problem before reconnecting the breaker.
2. Do not use a megger (insulation resistor) to test the drive control circuit. Failure to comply could cause drive damage.

Notice:

All the instruction photographs and diagrams of opened drive in this manual are only for illustration. Do not attempt to operate any AC drives with the cover opened.

1.2 Warning Label

The warning label is on the front of the drive. Please read it carefully and follow the instructions.

- Read the user manual before operation.
- Risk of electrical shock. Shut off main power and wait for 5 minutes before servicing.
- Hot surface. Risk of burn.

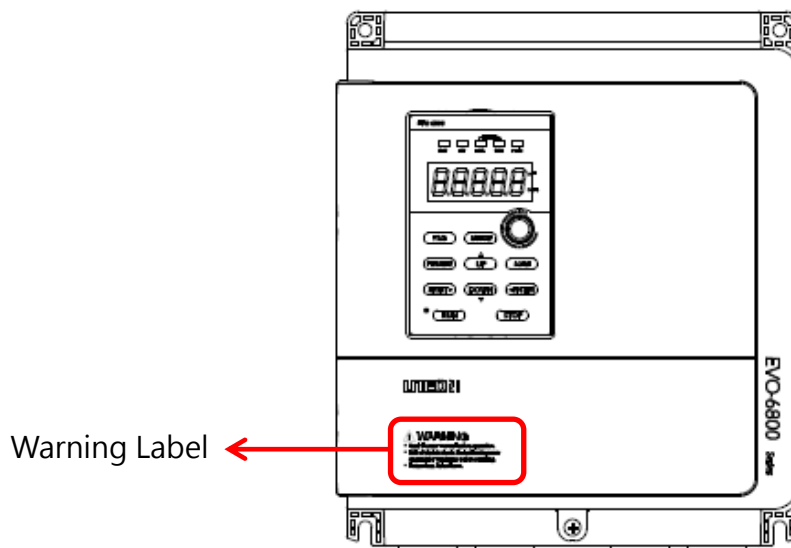

1.3 AC Drive Application Precautions

1.3.1 AC Drive Selection

1.3.1.1 Drive Capacity

Before driving motors, ensure the motor rated current is lower than the drive rated output. In addition, when a single AC drive is driving more than 1 motor in parallel, make sure the drive capacity is higher than 110% of total motor rated current.

1.3.1.2 Starting Torque

The motor characteristics at start and during acceleration are limited by the drive overcurrent. If higher starting torque is needed, use a higher rating drive or increase capacity of both motor and drive.

1.3.1.3 Emergency Stop

When a drive fault occurs, protection function will be automatically triggered to shut off the output but the motor may not stop immediately. Therefore please install mechanical brake if immediate stop is necessary.

1.3.2 Settings

1.3.2.1 Upper Limits

The maximum output frequency of the drive is 400Hz. If the upper limit is set incorrectly, the motor will run at higher than its rated speed and cause danger. Please set the limit of output frequency in Frequency Upper Limit parameter. The default setting of the rated output frequency is 60Hz.

1.3.2.2 DC Braking

Excessive DC braking current and duration could cause motor overheat.

1.3.2.3 Acceleration /Deceleration Time (Acc./Dec. Time)

Acceleration and deceleration time is determined by the motor torque, load torque and load inertia. Set a longer Acc./Dec. time after Stall Prevention function is triggered. In addition, the acceleration and deceleration time will be extended depending on the Stall Prevention duration. If faster acceleration and deceleration are required, install proper braking options or use a higher rating motor and AC drive.

1.3.3 General Handling

1.3.3.1 Wiring

Connecting power supply to output terminals U/T1, V/T2 and W/T3 will damage the drive. Check all the connections and wiring sequence before turning on the power. Failure to comply could cause drive damage.

1.3.3.2 Maintenance

Capacitors in the drive may still be charged for a short time after shutting off the power. Wait for the amount of time specified on the drive before any maintenance. Failure to comply could cause electrical shocks to personnel. Besides, do not touch the heatsink which can be very hot during operation. Replace the cooling fan only when the heatsink has cooled down after shutting off the power. In addition, when a synchronous motor is coasting to stop, it regenerates voltage to keep the drive terminals live even when the drive power is off. Wait until the motor is fully stopped before drive maintenance. Failure to comply could cause electrical shocks to personnel.

1.3.3.3 Wiring Tools

Use only the tools suggested by the terminal supplier during drive maintenance.

1.3.3.4 Transportation and installation

Do not expose the drive to the environment containing the halogens or DOP gas during transportation or installation.

1.4 Warranty

1.4.1 Warranty Period

Contact local distributor for details.

1.4.2 Warranty Restrictions

Warranty is not applicable when the drive is not properly used according to the manual regardless warranty period.

Chapter 2 | Product

2.1 Component Names

2.1.1 IP20 Enclosure

Frame 1

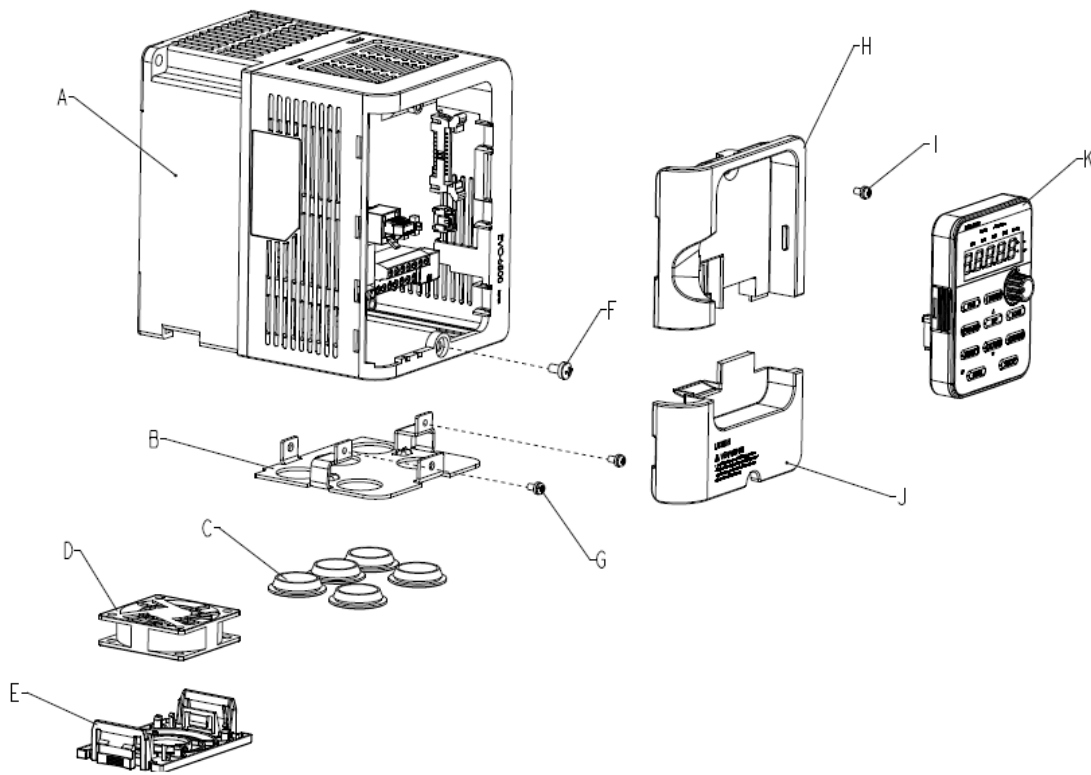

- A – Heatsink
- B – Conduit bracket
- C – Rubber bushing
- D – Cooling fan
- E – Cooling fan guard

- F – Terminal cover screw
- G – Conduit screw
- H – Front cover
- I – Front cover screw
- J – Terminal cover

- K – Keypad

Frame 2

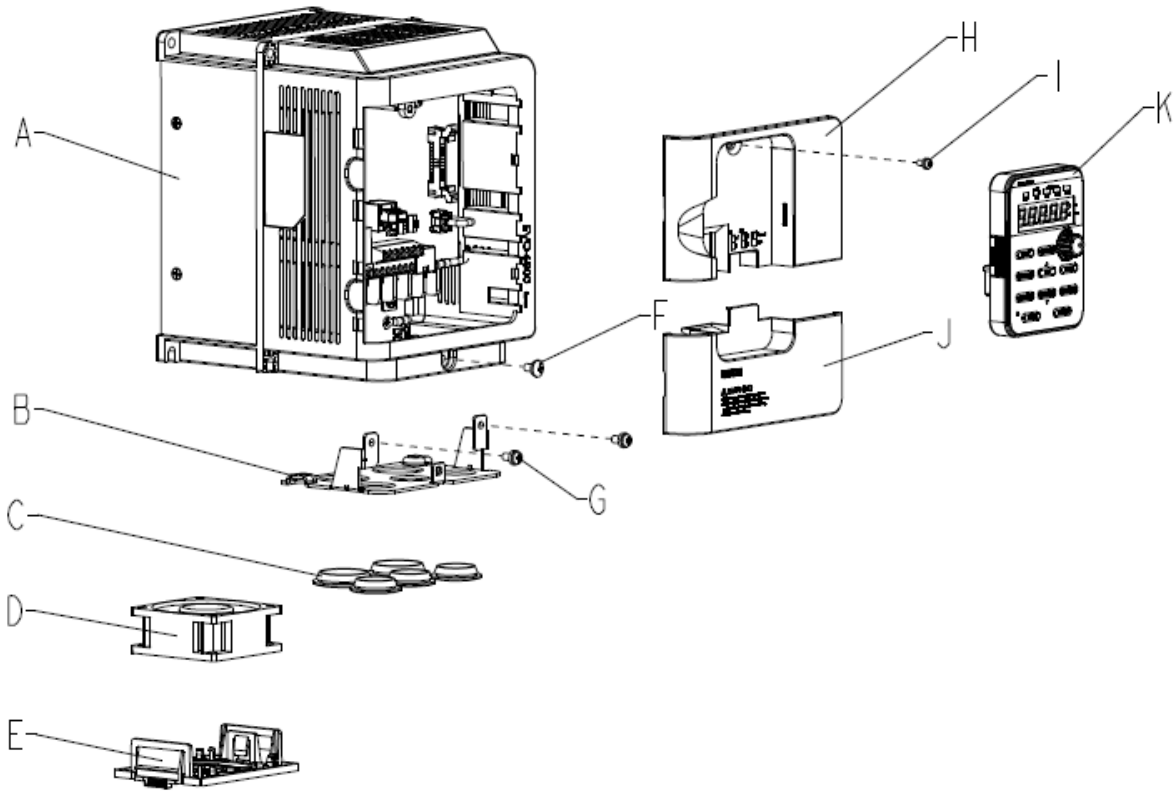

- A – Heatsink
- B – Conduit bracket
- C – Rubber bushing
- D – Cooling fan
- E – Cooling fan guard

- F – Terminal cover screw
- G – Conduit screw
- H – Front cover
- I – Front cover screw
- J – Terminal cover

- K – Keypad

Frame 3

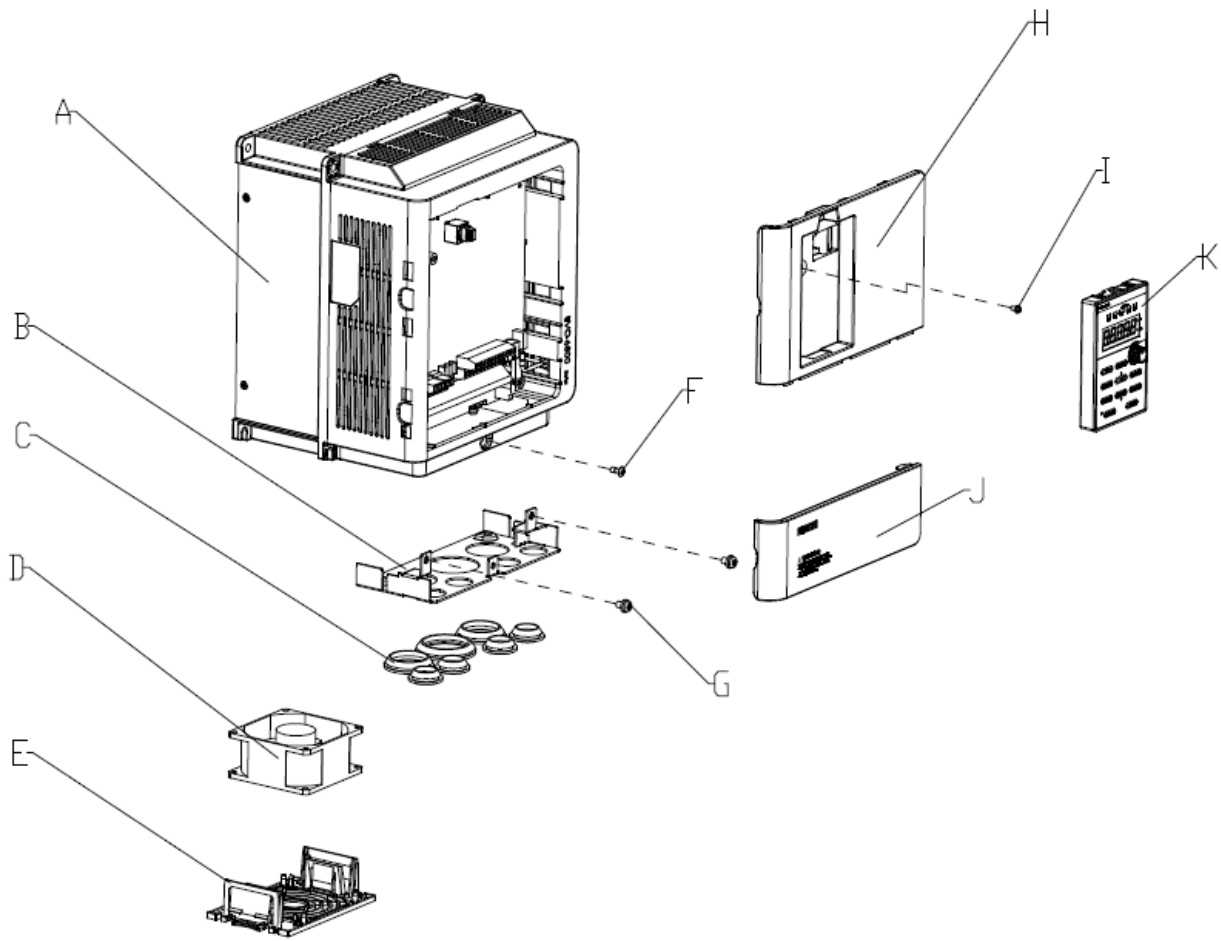

- A – Heatsink
- B – Conduit bracket
- C – Rubber bushing
- D – Cooling fan
- E – Cooling fan guard

- F – Terminal cover screw
- G – Conduit screw
- H – Front cover
- I – Front cover screw
- J – Terminal cover

- K – Keypad

2.1.2 NEMA Type 1 Enclosure

Frame 1

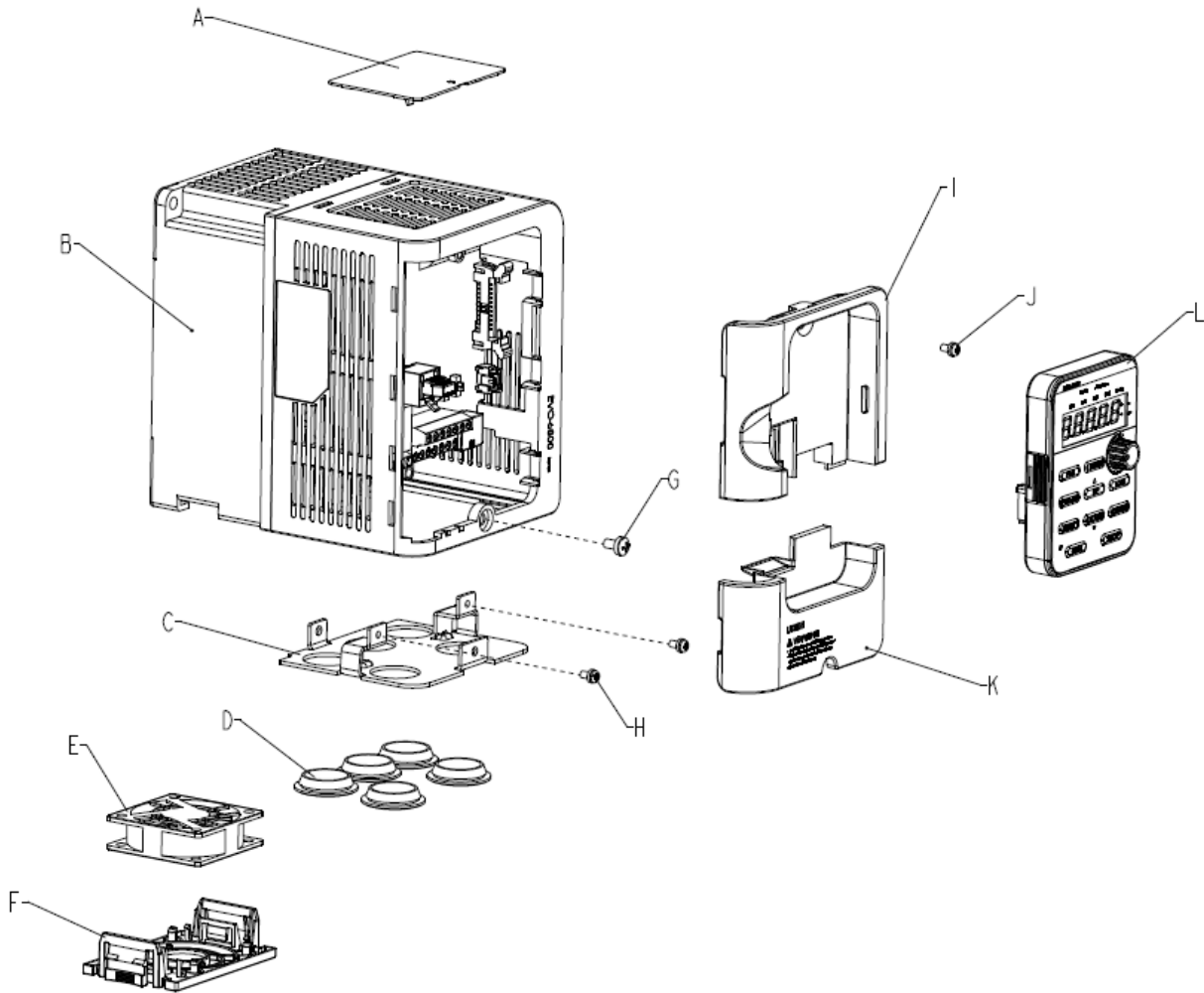

A – Top protective cover
B – Heatsink
C – Conduit bracket
D – Rubber bushing
E – Cooling fan
F – Cooling fan guard

G – Terminal cover screw
H – Conduit screw
I – Front cover
J – Front cover screw
K – Terminal cover

L – Keypad

Frame 2

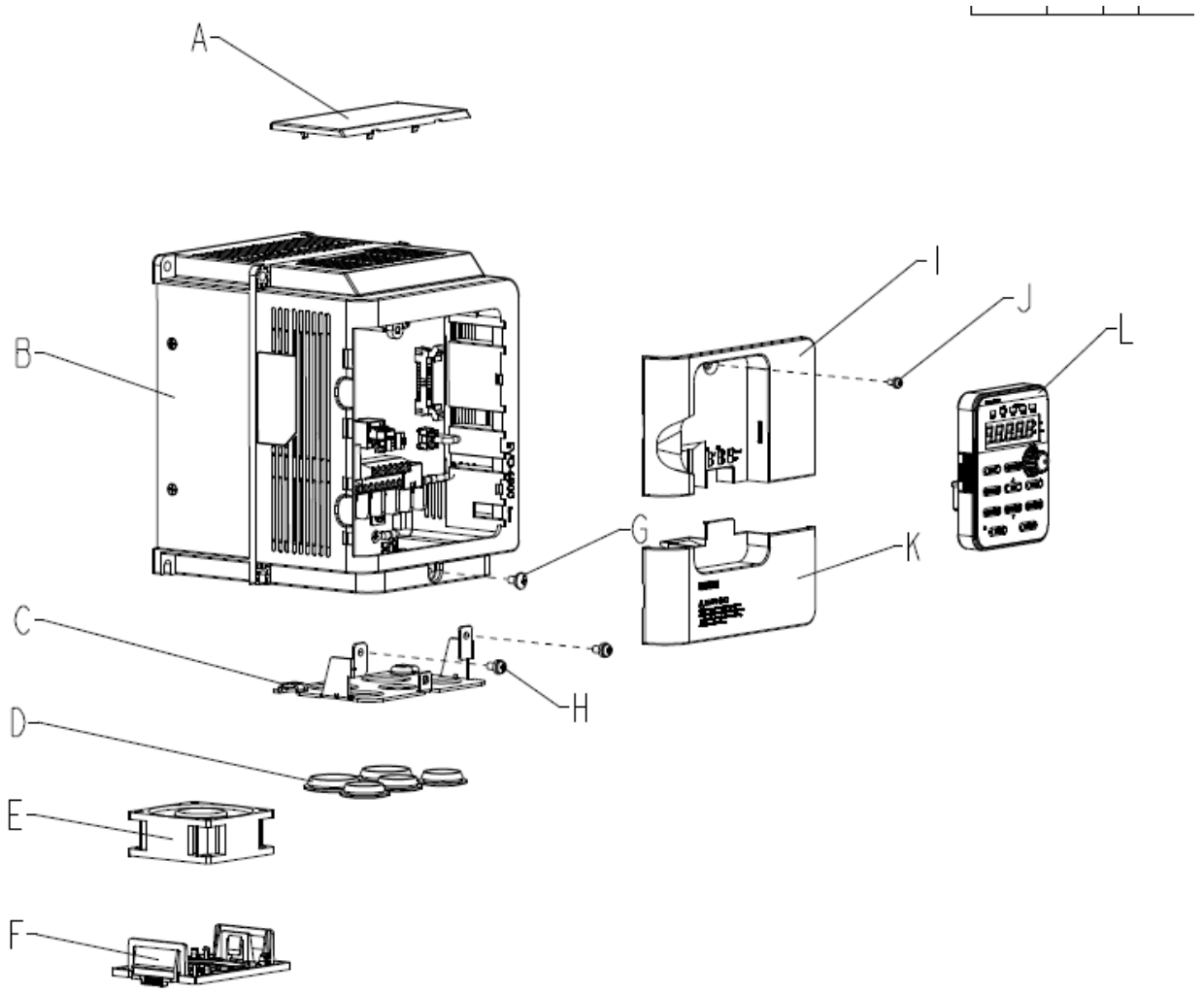

A – Top protective cover
B – Heatsink
C – Conduit bracket
D – Rubber bushing
E – Cooling fan
F – Cooling fan guard

G – Terminal cover screw
H – Conduit screw
I – Front cover
J – Front cover screw
K – Terminal cover

L – Keypad

Frame 3

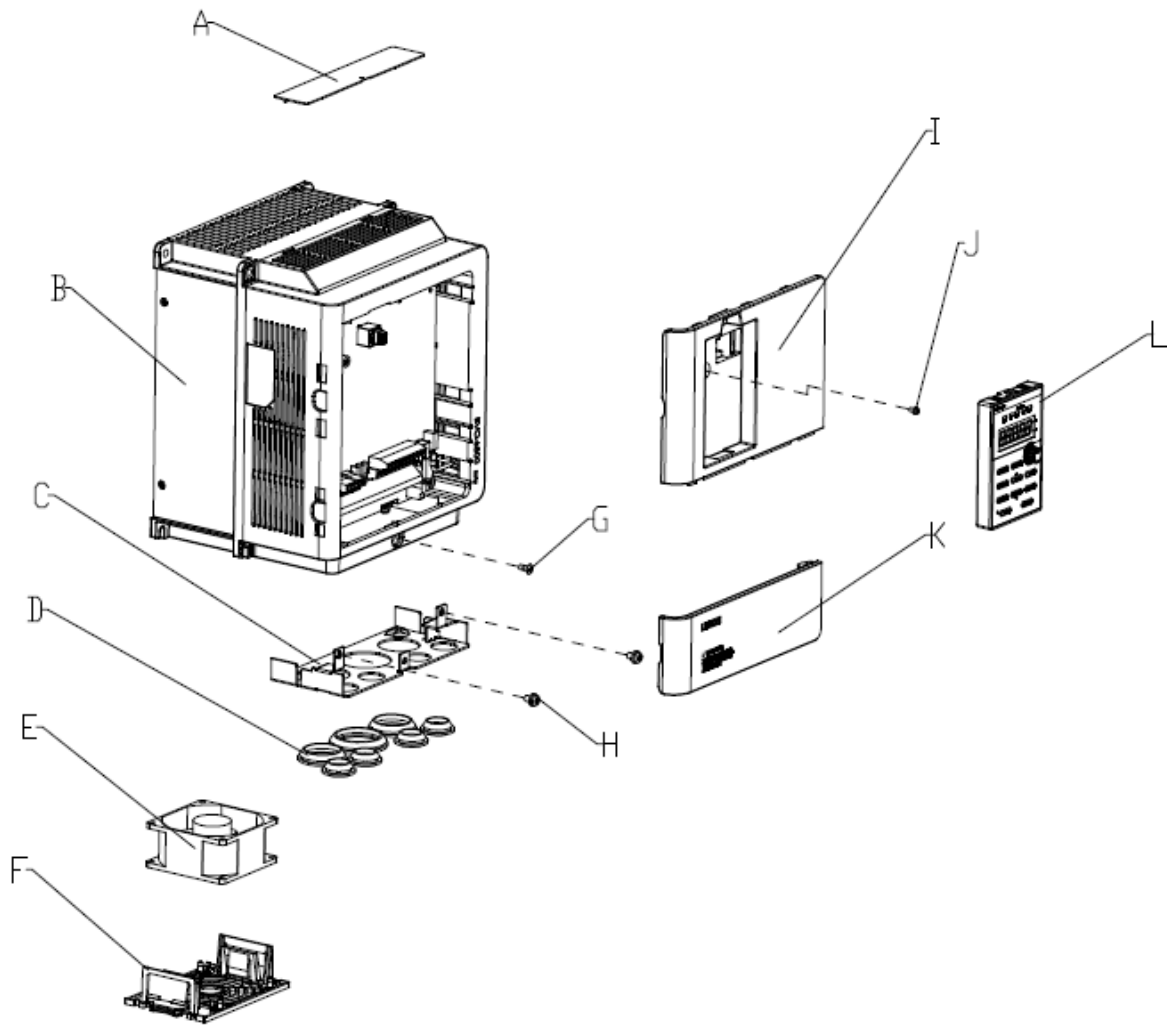

A – Top protective cover
B – Heatsink
C – Conduit bracket
D – Rubber bushing
E – Cooling fan
F – Cooling fan guard

G – Terminal cover screw
H – Conduit screw
I – Front cover
J – Front cover screw
K – Terminal cover

L – Keypad



2.2 Receiving Checklist

Check the following when receiving the drive:

1.	Is the packaging box in good condition? Any damage or damp? If so, contact the distributor or local Lite-On representative.
2.	Is the model label on the box same as what you purchased? If not, contact the distributor or local Lite-On representative.
3.	After opening the box, is there any damp mark inside the box? Any damage or crack on the drive enclosure? If so, contact the distributor or local Lite-On representative.
4.	Does the drive nameplate show the same model number as the carton label? If not, contact the distributor or local Lite-On representative.
5.	Are the manual and keypad in the carton? If not, contact the distributor or local Lite-On representative.

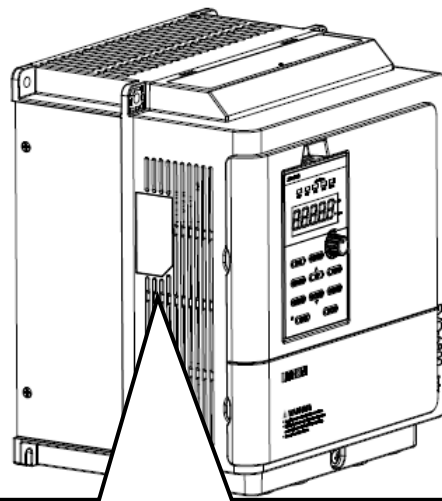
2.3 Nameplate



Model number	→	MODEL: EVO680043S7D5E20
Applicable motor rating	→	MOTOR RATING: 7.5kW/11kW
Input power supply	→	INPUT: AC3PH 380-480V 50/60Hz
Output power supply	→	OUTPUT: AC3PH 0-480V 0-400Hz 18.5A/25A
		 137D54315331D10001000001 IP20
		 CE LISTED IND. CONT. EQ. E466871
		 LITE-ON ELECTRONICS, INC.
		MADE IN TAIWAN

2.4 Model Number Definition

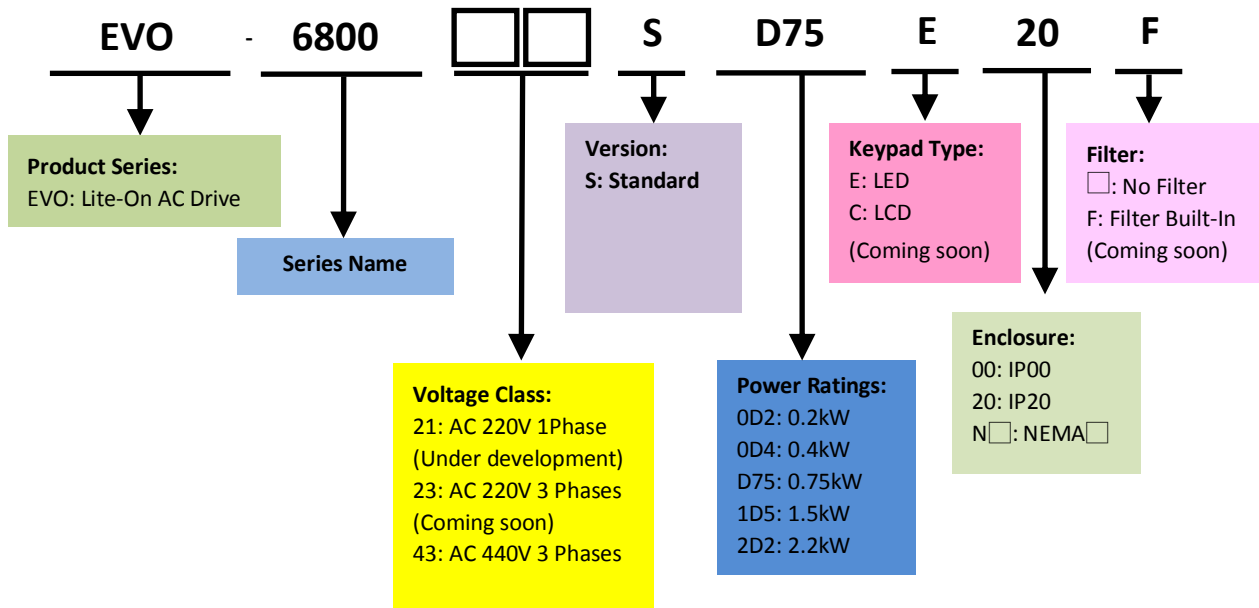

2.5 Power Ratings

		400V Class																			
Model No.	EVO680043S	D40	D75	1D5	2D2	3D7	5D5	7D5	011	015	018	022	030	037	045	055	075	090	110		
Max. Motor Capacity	HP	HD	0.5	1	2	3	5	7.5	10	15	20	25	30	40	50	60	75	100	125	150	
		ND	1	2	3	5	7.5	10	15	20	25	30	40	50	60	75	100	125	150	175	
	kW	HD	0.4	0.75	1.5	2.2	3.7	5.5	7.5	11	15	18.5	22	30	37	45	55	75	90	110	
		ND	0.75	1.5	2.2	3.7	5.5	7.5	11	15	18.5	22	30	37	45	55	75	90	110	132	
Voltage (V) / Frequency (Hz)		three phase, 380~480 V , -15% ~ +10% , 50/60Hz																			
Rated Output	Current (ND)		3.4	4.1	5.4	8	12.6	17	25	31	38	45	60	72	92	115	150	180	215	260	
	Current (HD)		1.8	3.4	4.2	5.5	9.5	12.6	18.5	25	32	38	45	60	75	92	115	150	180	215	
	Output Frequency(Hz)		0~400 Hz																		
	Carrier Frequency (kHz)		2~12							1~15											
Cooling Method		Fanless		Fan																	
Frame Size		0	1	2	3	4	5	6	7												

2.6 Common Specifications

Item		Specification
Control Characteristic	Control Method	V/F, Sensorless Voltage Vector Control (SVVC)
	Output Frequency	0 to 400 Hz
	Frequency Accuracy	Digital Input: Within $\pm 0.01\%$ of the max. output frequency
		Analog Input: Within $\pm 0.1\%$ of max. output frequency (-10°C to +50°C)
	Frequency Setting Resolution	Digital Input : 0.01Hz
		Analog Output: 1/1000 of max. frequency
	Starting Torque ^{*1}	150% / 3Hz (V/F)
		200% / 0.3Hz (IM Sensorless Voltage Vector Control)
	Speed Control Range ^{*1}	1: 40 (V/F)
		1:200 (IM Sensorless Voltage Vector Control)
	Speed Control Accuracy ^{*1}	$\pm 0.2\%$ (Sensorless Voltage Vector Control)
	Speed Response	Over 5Hz (Sensorless Voltage Vector Control)
	Acc/Dec Time	0.0 to 6000.0
Braking Torque	Approx. 20%	
Filter	Options C2 (<7.5kW) · C3 (>11KW)	
V/F Pattern	15 fixed patterns and 1 programmable pattern	
Overload Capacity	120% for 1 min. in every 10 min. (Normal Duty)	
	150% for 1 min. in every 10 min. (Heavy Duty) 180% for 10 sec.. in every 10 min. (Heavy Duty) 200% for 1 sec.. in every 10 min. (Heavy Duty)	
Operating Environment	Area of Use	Indoor without corrosive gas/liquid or flammable gas/liquid/oil mist/dust
	Ambient Temperature	-10°C to +50°C, -10°C to +40°C (NEMA1), below 90% RH without froze or condensation
	Storage Temperature	-20°C to +60°C
	Altitude	Up to 1000 meters
	Shock	10 to 20 Hz (9.8 m/s ²) , 20 to 55 Hz (5.9 m/s ²)

	Enclosure	IP20, NEMA1 (with optional NEMA kit)
Number of I/O (<5.5kW models)	Analog Input (AI)	1 points (AI2: 0V~10V, 0/4~20mA)
	Digital Input (DI)	4 points
	Analog Output (AO)	1 points (0~10V/0or4~20mA)
	Digital Output (DO)	1 points
	Relay Output (RO)	1 points
	Pulse Input (PI)	1 point
	Pulse Output (PO)	N/A
Number of I/O (>7.5kW models)	Analog Input (AI)	2 points (AI1: -10V~10V, 0~10V AI2: 0V~10V, 0/4~20mA)
	Digital Input (DI)	7 points(1 DI support PI 50kHz*)
	Analog Output (AO)	2 points(AM:0~10V/0or4~20mA · FM:0~10V/-10~+10V)
	Digital Output (DO)	1 point
	Relay Output (RO)	2 points
	Pulse Input (PI)	1 point(1 DI support PI 50kHz*)
	Pulse Output (PO)	1 point
Communications		Modbus (RS-485 port), Max. high speed is 115.2kbbs
Communication Option Card		Profibus-DP · CANopen · EtherCAT

*1. Results tested in labs

2.7 Product Dimensions

Frame 1

EVO680043S1D5E20 · EVO680043S2D2E20

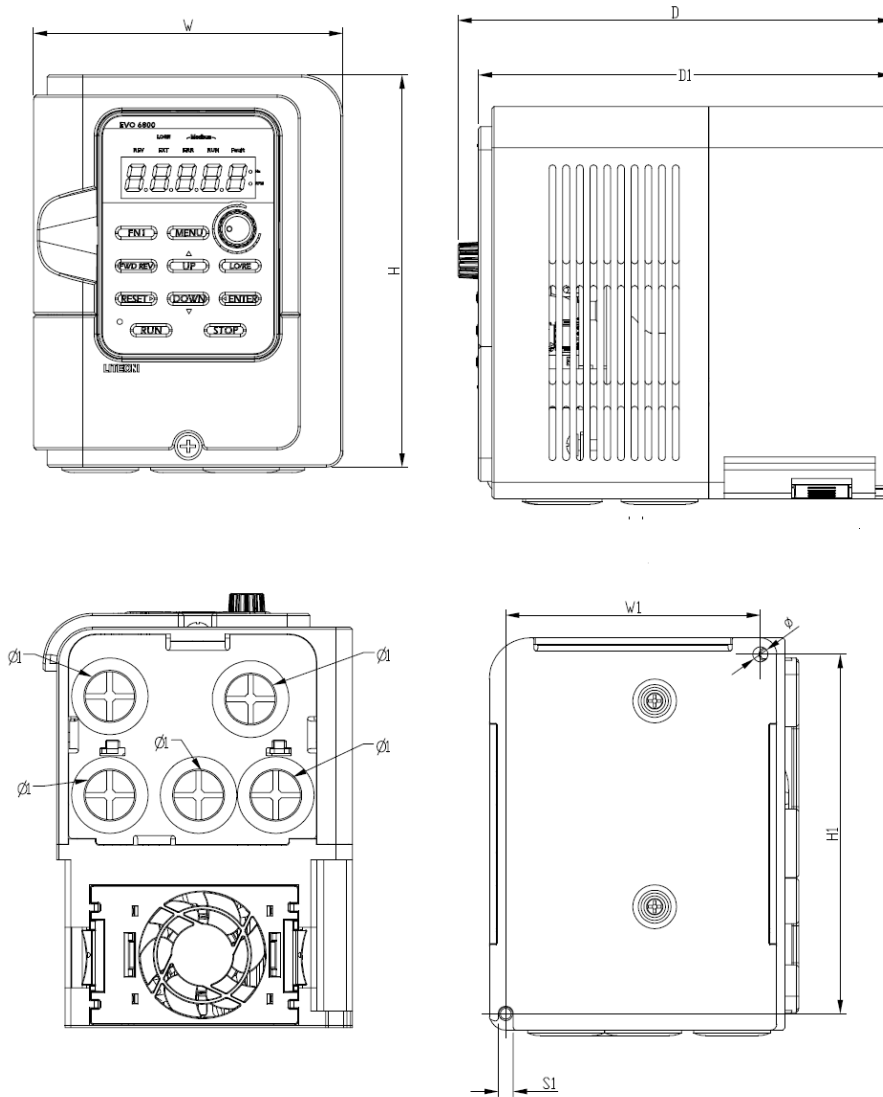

Series	Frame	W	W1	H	H1	D	D1	S1	ϕ	$\phi 1$	$\phi 2$
EVO6800	1	113	93	143	131	158.4	151	5.5	5.5	22	22
		[4.45]	[3.66]	[5.63]	[5.16]	[6.24]	[5.89]	[0.22]	[0.22]	[0.87]	[0.87]

Frame 2

EVO680043S3D7E20 · EVO680043S5D5E20

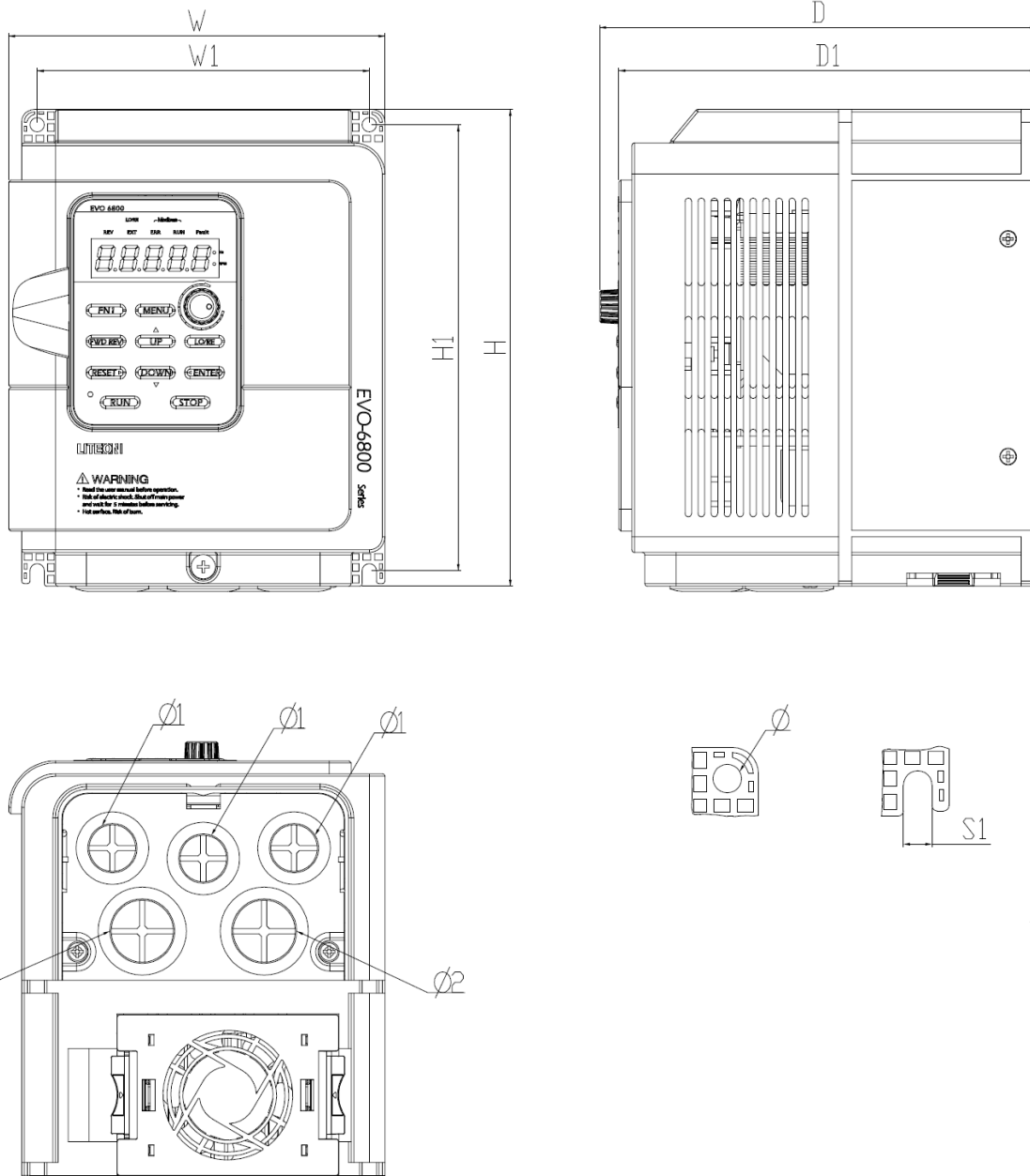

Series	Frame	W	W1	H	H1	D	D1	S1	Φ	$\Phi 1$	$\Phi 2$
EVO6800	2	145	128	184	172	168	161	5.5	5.5	22	28
		[5.71]	[5.04]	[7.25]	[6.77]	[6.56]	[6.34]	[0.22]	[0.22]	[0.87]	[1.10]

Frame 3

EVO680043S7D5E20 · EVO680043S011E20

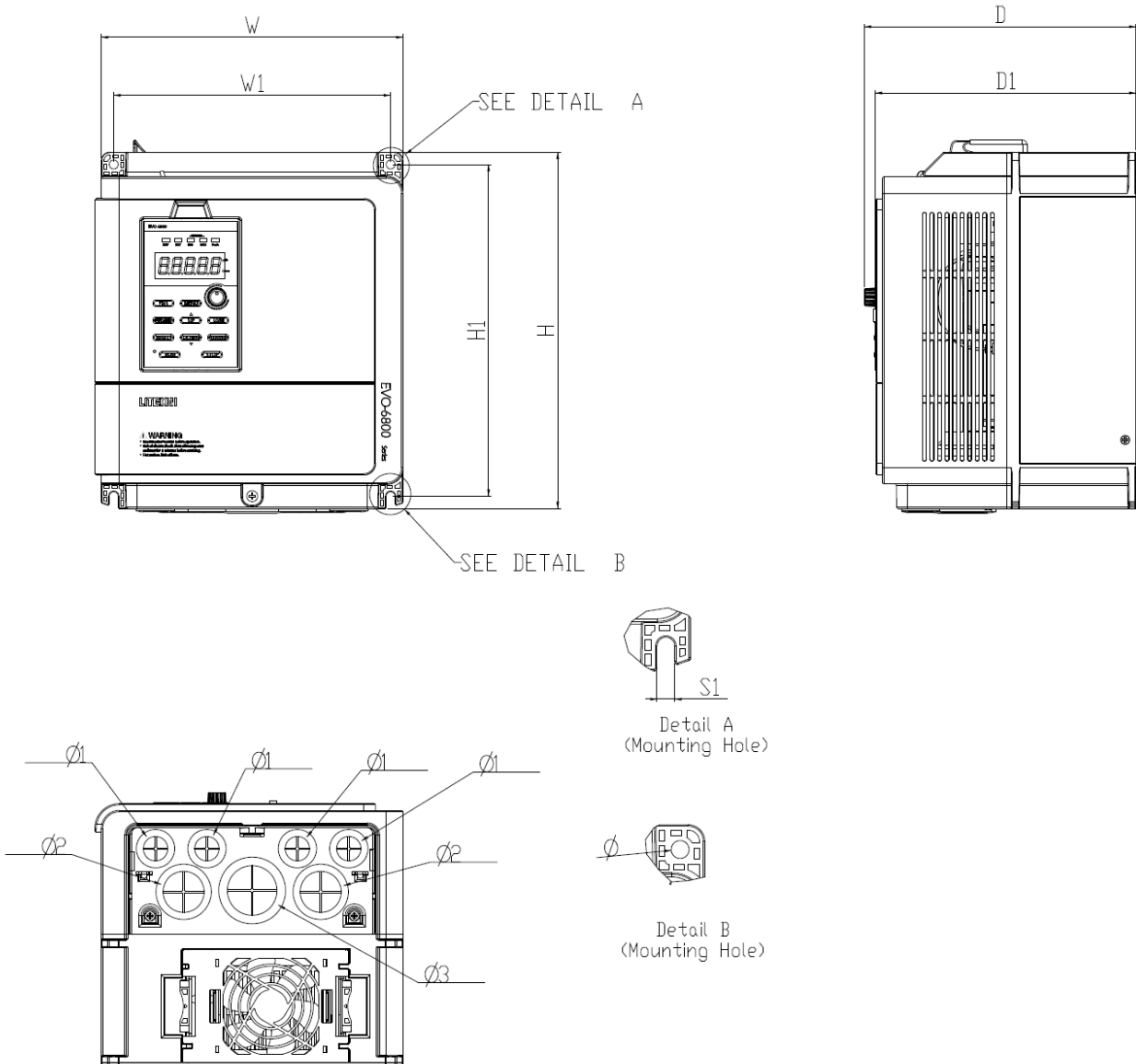

Series	Frame	W	W1	H	H1	D	D1
EVO6800	3	225[8.79]	202[7.89]	260[10.16]	242[9.46]	198[7.74]	190[7.42]
		S1	ϕ	$\phi 1$	$\phi 2$	$\phi 3$	
		6.5[0.25]	6.5[0.25]	22[0.86]	35[1.36]	44[1.73]	

Frame 4

EVO680043S015E20、EVO680043S018E20

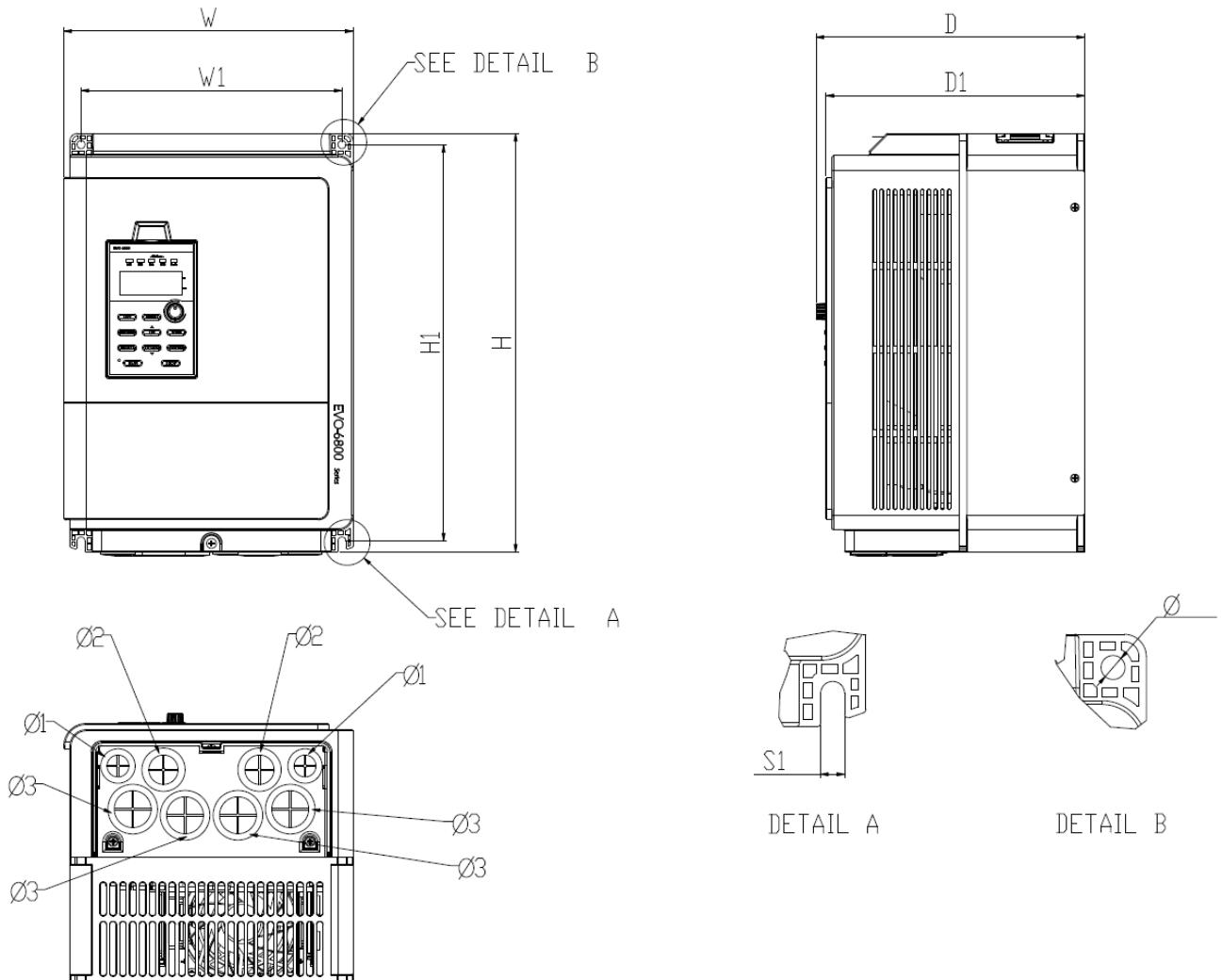

Series	Frame	W	W1	H	H1	D	D1
EVO6800	4	235[9.25]	212[8.35]	340[13.38]	322[12.68]	218.2[8.59]	210[8.27]
		S1	Φ	$\Phi 1$	$\Phi 2$	$\Phi 3$	
		6.5[0.26]	6.5[0.26]	22[0.87]	28[1.10]	35[1.38]	

Frame 5

EVO680043S022E20、EVO680043S030E20

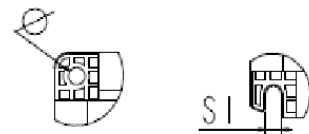
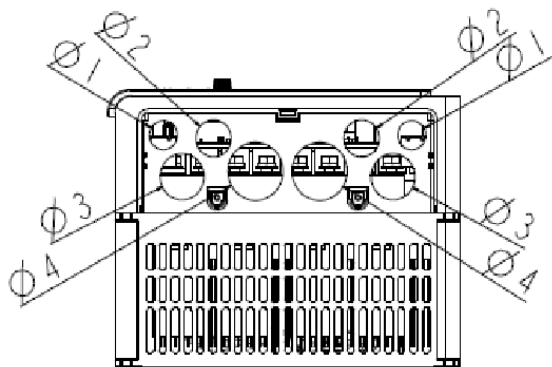
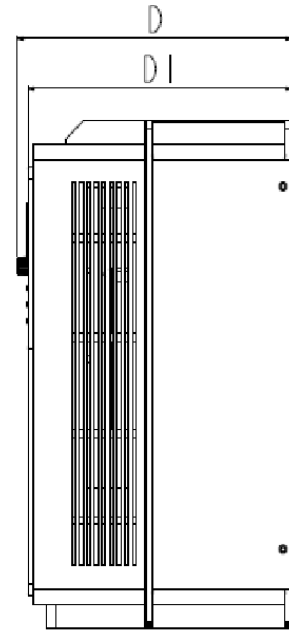
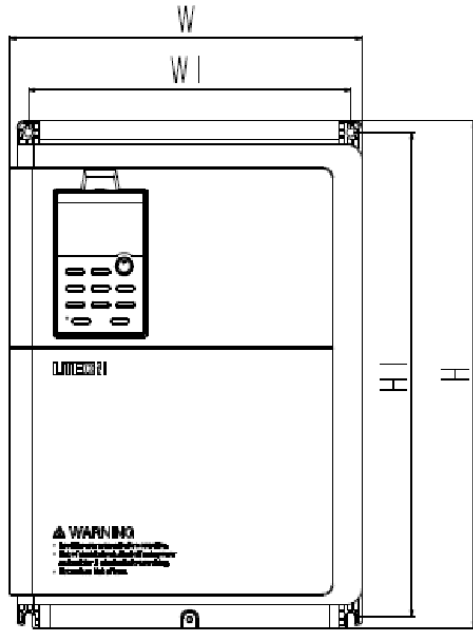

Series	Frame	W	W1	H	H1	D	D1
EVO6800	5	281[10.397]	257[10.03]	385[15.03]	367[14.33]	218.9[8.55]	211[8.24]
		S1	Φ	Φ1	Φ2	Φ3	Φ4
		6.5[0.26]	6.5[0.26]	22[0.87]	28[1.10]	35[1.38]	44[1.72]

Frame 6

EVO680043S037E20、EVO680043S045E20、EVO680043S055E20

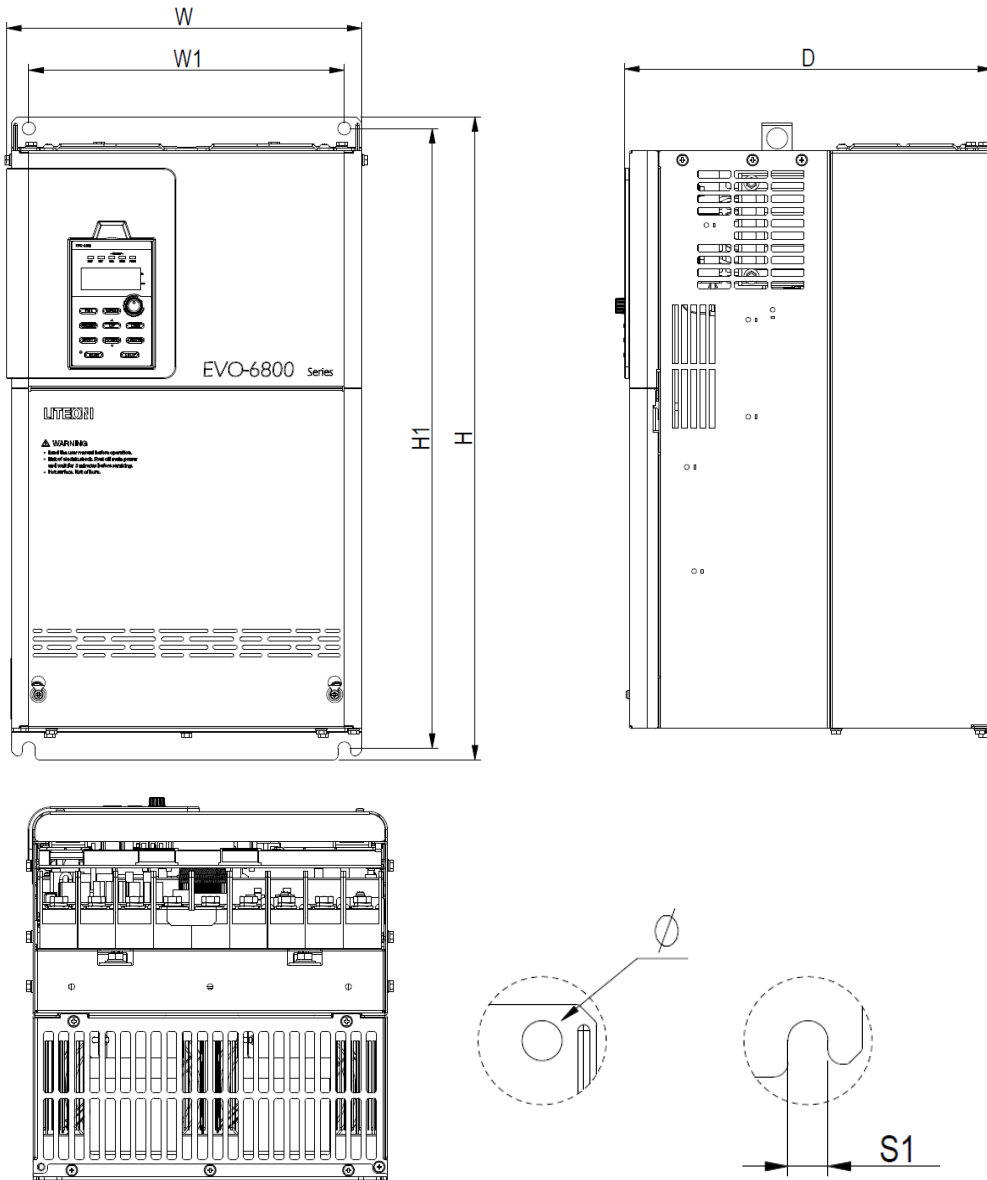

框架7

Series	Frame	W	W1	H	H1	D	S1
EVO6800	6	304[11.88]	270[10.55]	550[21.48]	530[20.70]	315[12.30]	11[0.43]
		Φ					
		11[0.43]					

Frame 7

EVO680043S075E20、EVO680043S090E20、EVO680043S0110E20

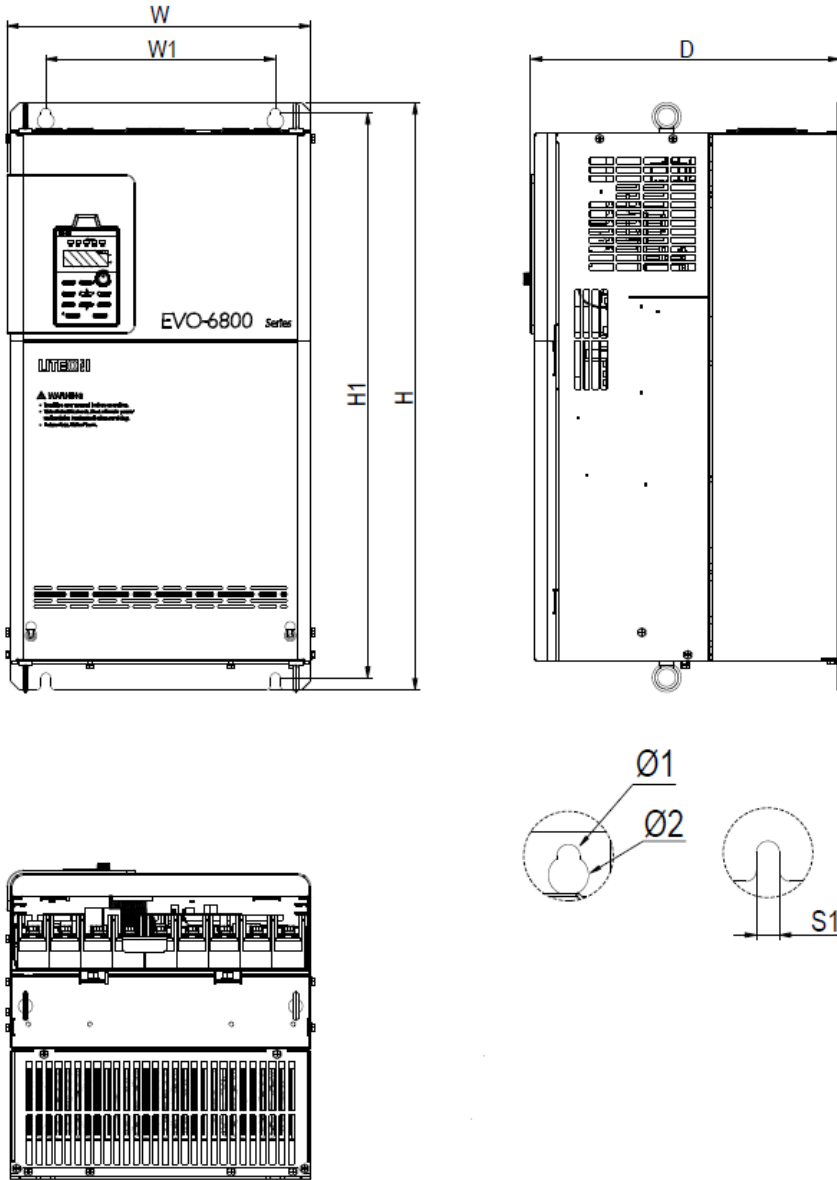

Series	Frame	W	W1	H	H1	D	S1
EVO6800	7	344[13.43]	260[10.15]	665[25.97]	640[25.00]	350[13.67]	11[0.43]
		Φ1	Φ2				
		11[0.43]	19[0.74]				

2.8 Options

2.8.1 Options

EVO Series Common Accessories		
Name	Model Number	Description
Copy Unit	EVO-Kit-CU	Allows parameter uploads / downloads and comparison

2.8.2 Braking Unit

Applicable Motor		125% Braking Torque 10%ED			* ² Max. Braking Torque Limit		
HP	kW	Braking Torque (kg-m)	HP	kW	Braking Torque (kg-m)	HP	kW
2	1.5	1.0	200W/360Ω	2.4	200	3.9	3
3	2.2	1.5	300W/250Ω	3.5	130	5.8	4.4
5	3.7	2.5	500W/150Ω	5.9	80	9.7	7.4
7.5	5.5	2.7	800W/100Ω	8.8	56	14.5	11
10	7.5	5.1	1000W/75Ω	10.5	45.1	17.5	13.8
15	11	7.5	1600W/50Ω	15.8	45.1	17.5	13.8
20	15	10.2	2000W/40Ω	19.8	22.6	35	27.7
25	18.5	12.2	2500W/32Ω	24.7	22.6	35	27.7
30	22	14.9	3000W/26Ω	30.4	22.6	35	27.7
40	30	20.3	4000W/20Ω	39.5	14.1	56	44.2

2.8.3 Filiter

Model Name	Power Rating (KW) (HD)	Rating Current (A) (ND)	Filiter Selection (PE 3200 Series)
three phase, 380~480 V , -15% ~ +10% , 50/60Hz			
EVO680043S1D5	1.5	5.87	PE3200-10-01
EVO680043S2D2	2.2	6.56	PE3200-10-01
EVO680043S3D7	3.7	14.29	PE3200-16-01
EVO680043S5D5	5.5	18.07	PE3200-20-01
EVO680043S7D5	7.5	31	PE3200-35-01
EVO680043S011	11	37.4	PE3200-50-01
EVO680043S015	15	46.5	PE3200-50-01
EVO680043S018	18	53	PE3200-65-01
EVO680043S022	22	68.7	PE3200-80-01
EVO680043S030	30	82	PE3200-100-01
EVO680043S037	37	100	PE3200-100-01
EVO680043S045	45	125	PE3200-130-01
EVO680043S055	55	165	PE3200-200-01
EVO680043S075	75	200	PE3200-200-01

Note : This table is for reference only

Chapter 3 | Drive Installation

3.1 Installation Environment

To ensure the optimum drive performance, install the AC drive in a proper environment specified below.

Environment	Conditions
Area of Use	Indoors
Ambient Temperature	<ul style="list-style-type: none"> ● -10°C to +40°C (NEMA 1 enclosure) ● -10°C to +50°C (IP20 enclosure) ● Do not install the drive in environments with wide temperature fluctuations so as to ensure the drive reliability. ● When the drive is installed in an enclosure cabinet, make sure the cooling works properly to keep the temperature within the specified levels. ● Do not allow the drive to freeze. ● When drives are installed side-by-side in a cabinet, follow the instruction illustrated in Figure 3.2 to ensure the air flow.
Humidity	<ul style="list-style-type: none"> ● Under 90% RH ● Free of condensation
Storage Temperature	-20°C to +60°C
Surrounding Area	<ul style="list-style-type: none"> ● Free from water, oil, metal shavings or other foreign materials. ● Free from flammable materials (e.g., wood) ● Free from harmful gases and liquids ● Free from direct sunlight ● Free from oil mist, corrosive gas, flammable gas or dust. ● Free from radioactive material ● Green Class 2 or above
Altitude	Up to 1000 m without derating. Up to 2000 meters with 1% rated current derated for every 100 m counted from 1000 m.
Vibration	<ul style="list-style-type: none"> ● 10 to 20 Hz at 9.8 m/s² ● 20 to 55 Hz at 5.9 m/s² (2A0004 to 2A0211, 4A0002 to 4A0165) , or 2.0 m/s² (2A0250 to 2A0415, 4A0208 to 4A1200)
Enclosure	IP20/NEMA 1.

3.2 Installation Direction and Spacing

3.2.1 Installation Direction

Install the AC drive upright for better cooling.

Figure 3.1 Installation Direction

OK

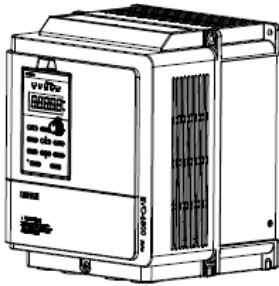

a. Upright installation

NG

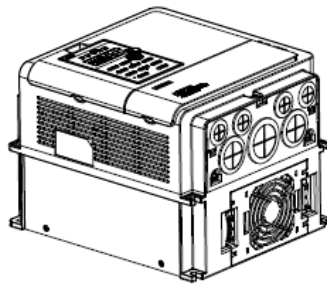

b. Horizontal installation

NG

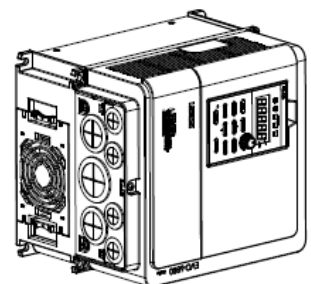

c. Transverse installation

3.2.2 Installation Spacing

3.2.2.1 Single Drive Installation

Install the AC drive as illustrated below to ensure the required space for airflow and wiring.

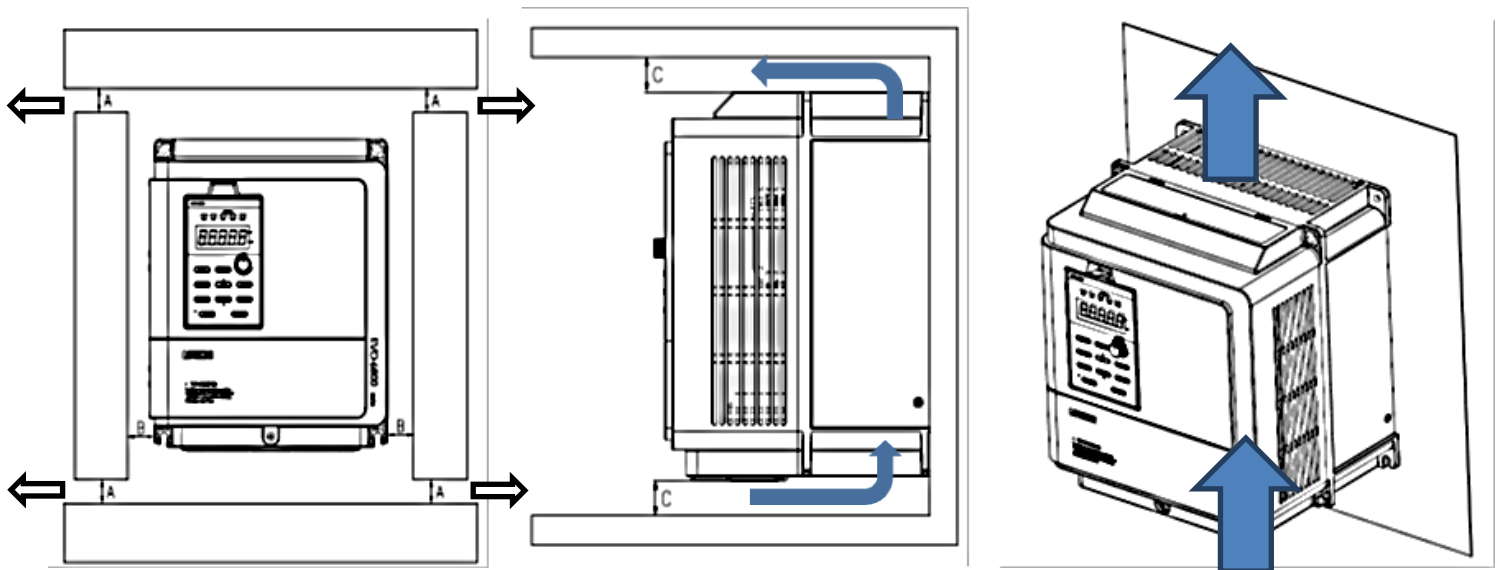
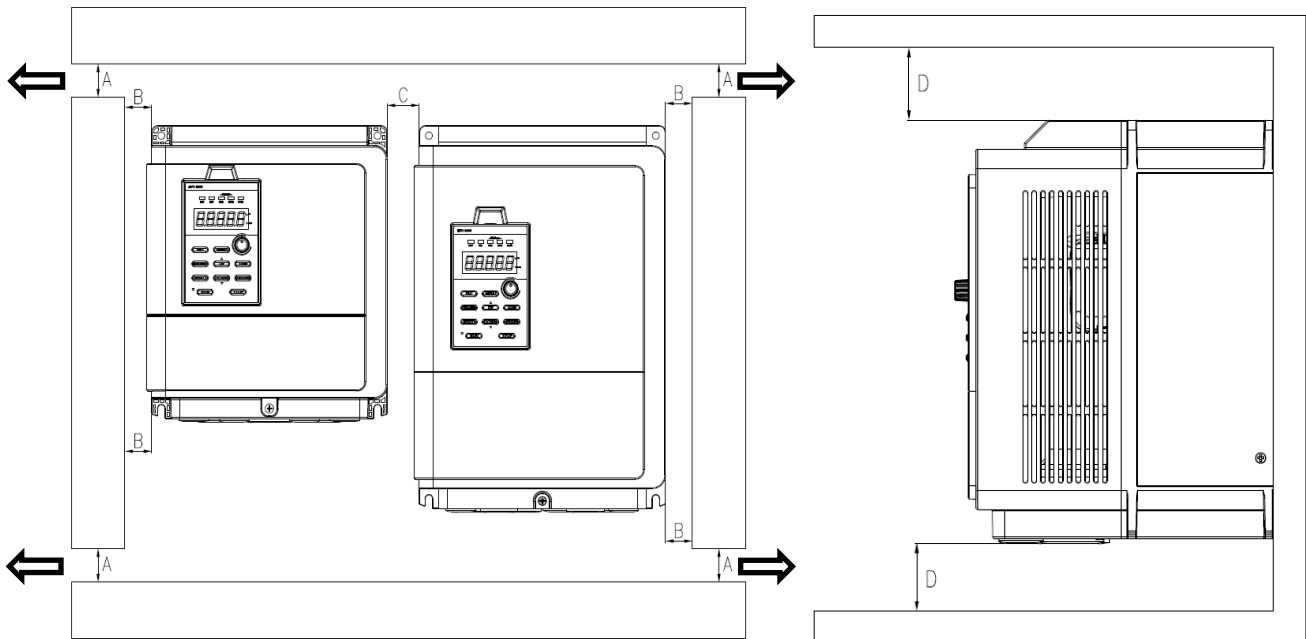

Figure 3.2 Installation Spacing for Single Drive

Note: Same amount of space is required for IP00 and NEMA 1 enclosure.

3.2.2.2 Side-by-Side Installation

Install the AC drives as illustrated below to ensure the required space for airflow and wiring.



A – Minimum 50 mm B - Minimum 30 mm C - Minimum 10 mm D - Minimum 150 mm

Figure 3.3 Installation Space for Side-by-Side Installation

Note: When installing drives of different sizes, align the tops of the drives for easier cooling fan replacement.

3.3 Keypad and Terminal Cover Installation

It is not necessary to remove the keypad before wiring. You just need to loosen the terminal cover screw and remove the terminal cover.

440V 1 to 40HP model enclosure are non-metal. Loosen terminal cover screw and remove terminal cover for wiring. After wiring, affix the terminal cover back in position and tighten the screw. For wiring instructions and screw tightening torque please refer to Chapter 4.

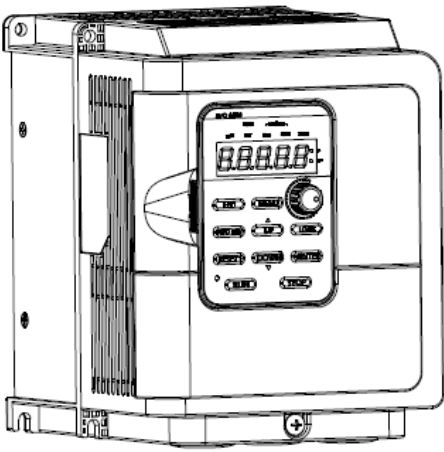

Step1: Loosen front screw

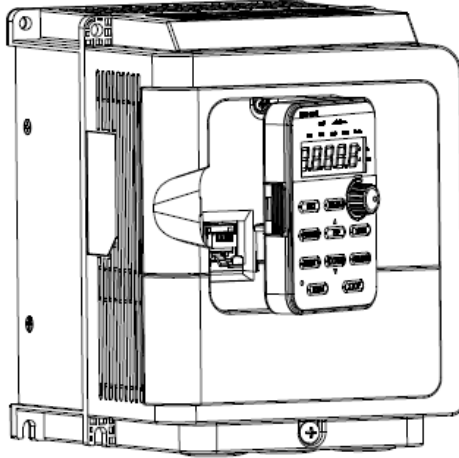

Step2: take out the keypad

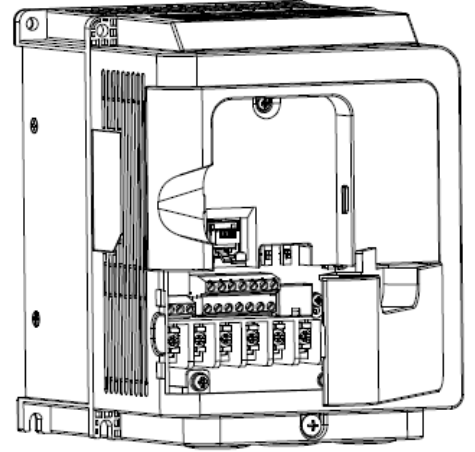

Step3: Remove the terminal cover

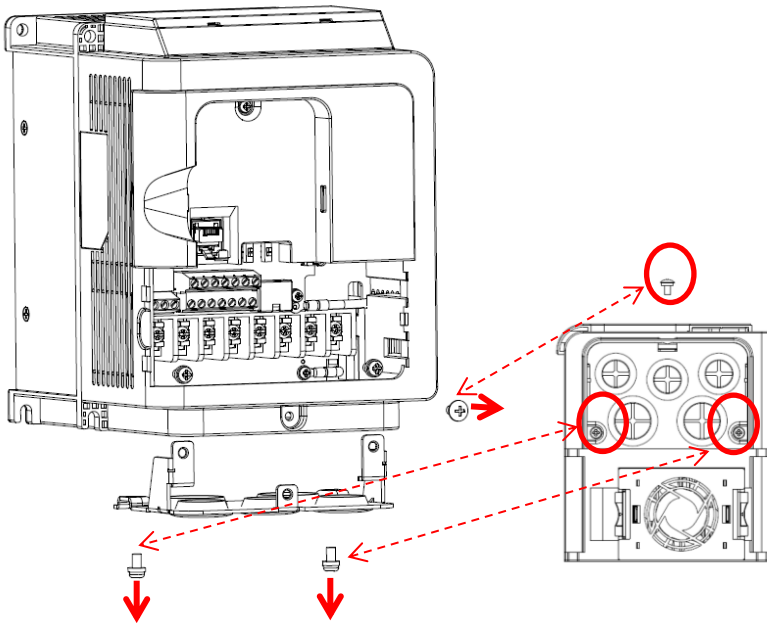

Step4: Loosen screws of the wiring cover and remove the wiring cover

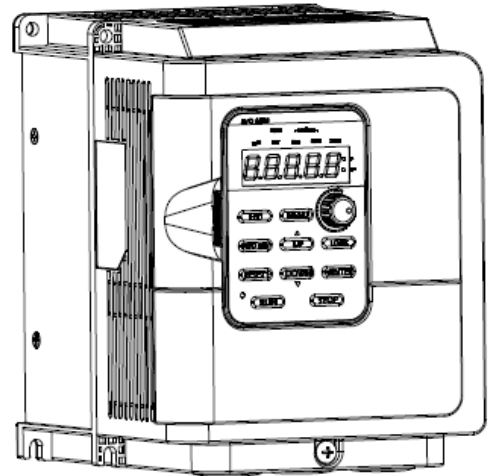

Step5: locking screw, replace the controller and wiring cover

3.4 Wiring Protection

3.4.1 Drive and Input Cable Protection for Short-Circuit Situations

Protect the drive and input power cable by using fuse in case potential short-circuit situations cause overheating. Please refer to the following figure for proper wiring.

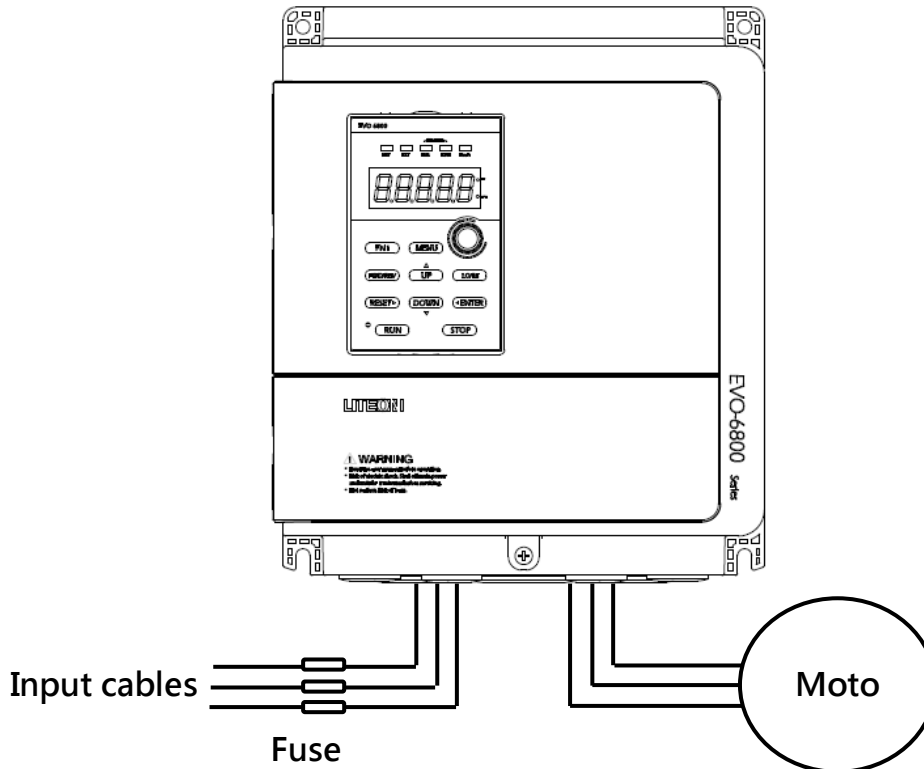

Figure 3.4 Fuse Installation

3.4.2 Motors and Output Cable Protection for Short-Circuit Situations

If the output cables are properly selected according to the drive rated current, the drive itself is fully capable of protecting the motor and output cables in case of short-circuit situations.

Note: If a single drive runs more than 1 motor, a separate thermal overload switch or a circuit breaker is required.

3.5 Keypad Remote Usage

Keypad mounted on the drive can be removed and connected to the drive using an extension cable to facilitate operation when the drive is installed in a location where it cannot be easily accessed. It can also be permanently mounted remote locations such as panel doors using an extension cable and an installation support set.

3.5.1 Remote Operation

3.5.1.1 Remote Operation (<5.5kW models)

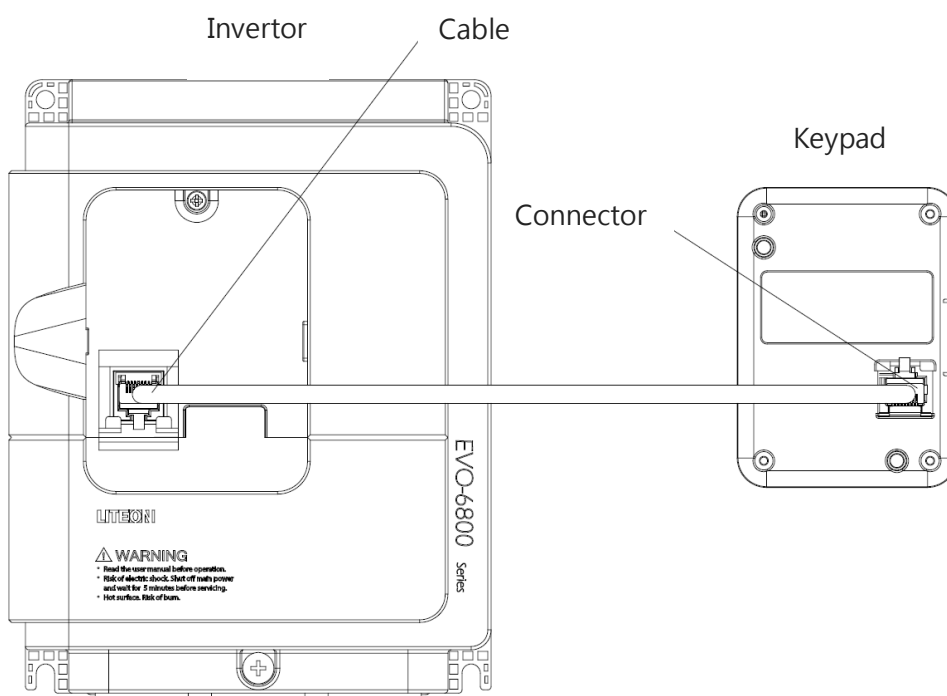

3.5.1.2 Remote Operation (>7.5kW models)

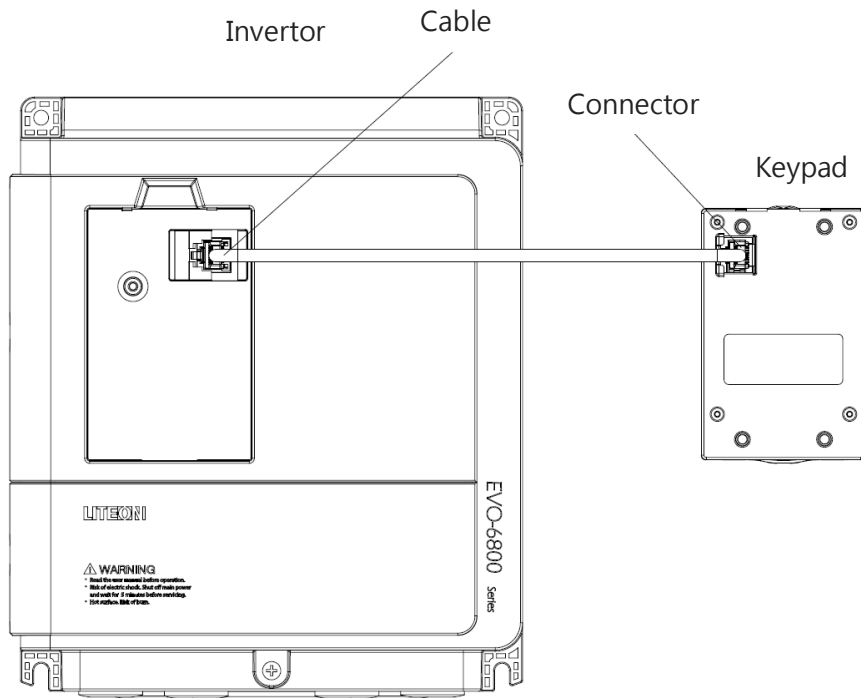

3.5.1.3 Keypad Dimensions (<5.5kW models)

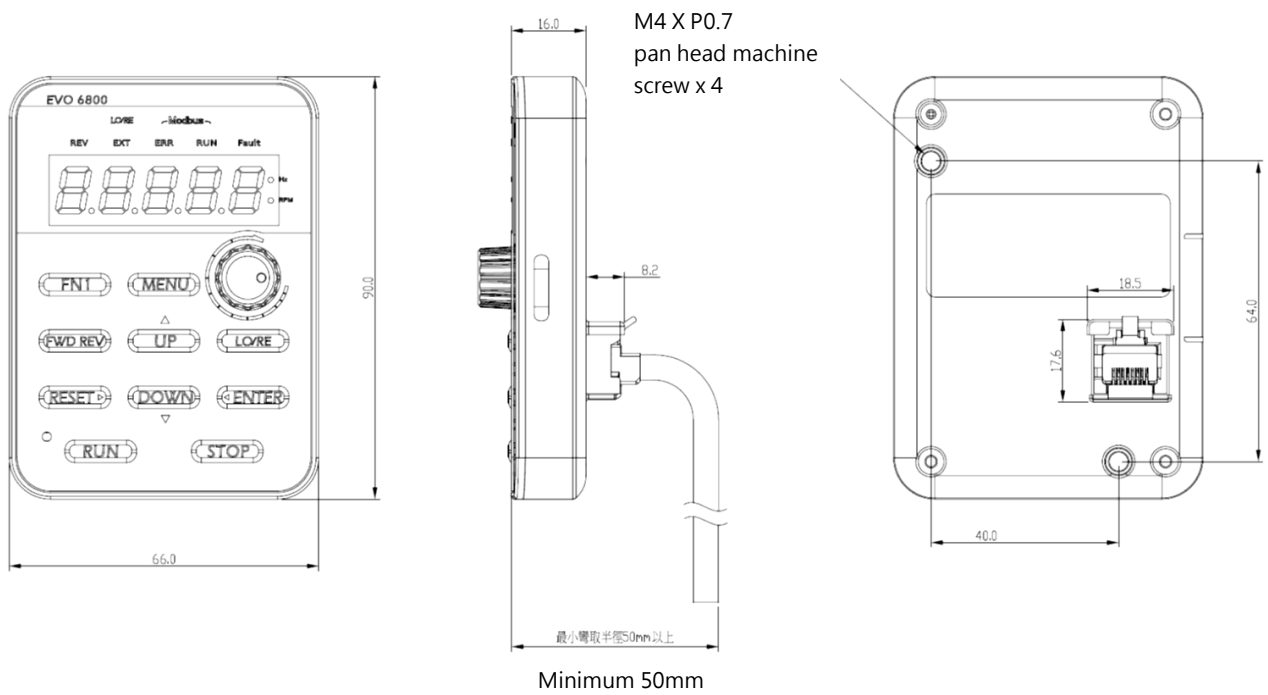

3.5.1.4 Keypad Dimensions (>7.5kW models)

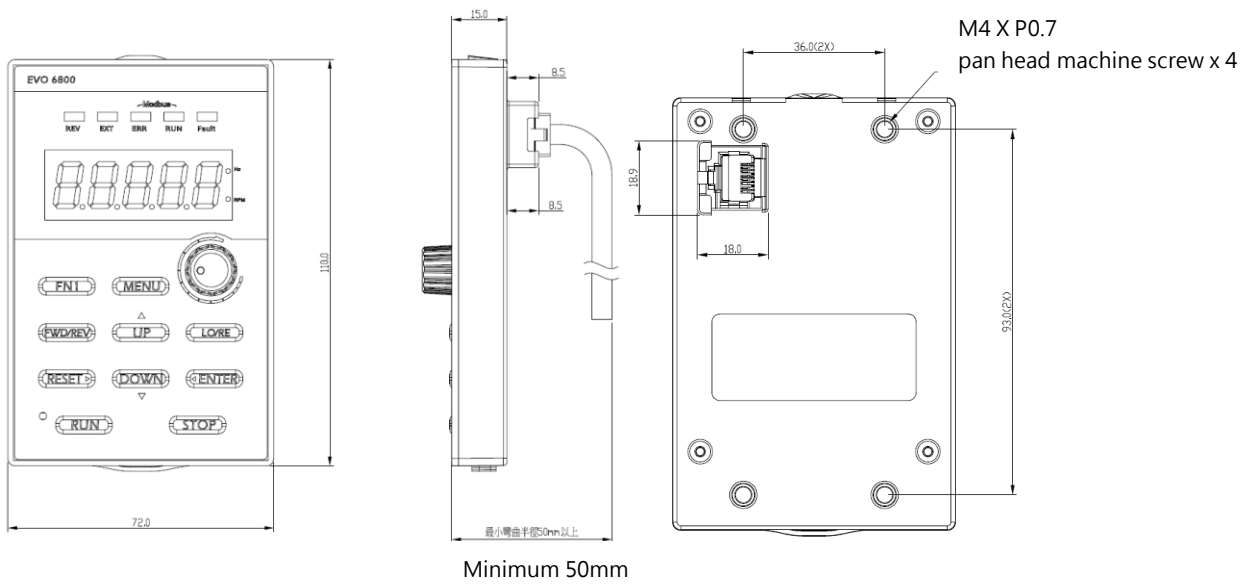

3.5.2 External/Face-Mount

3.5.2.1 External/Face-Mount (<5.5kW models)

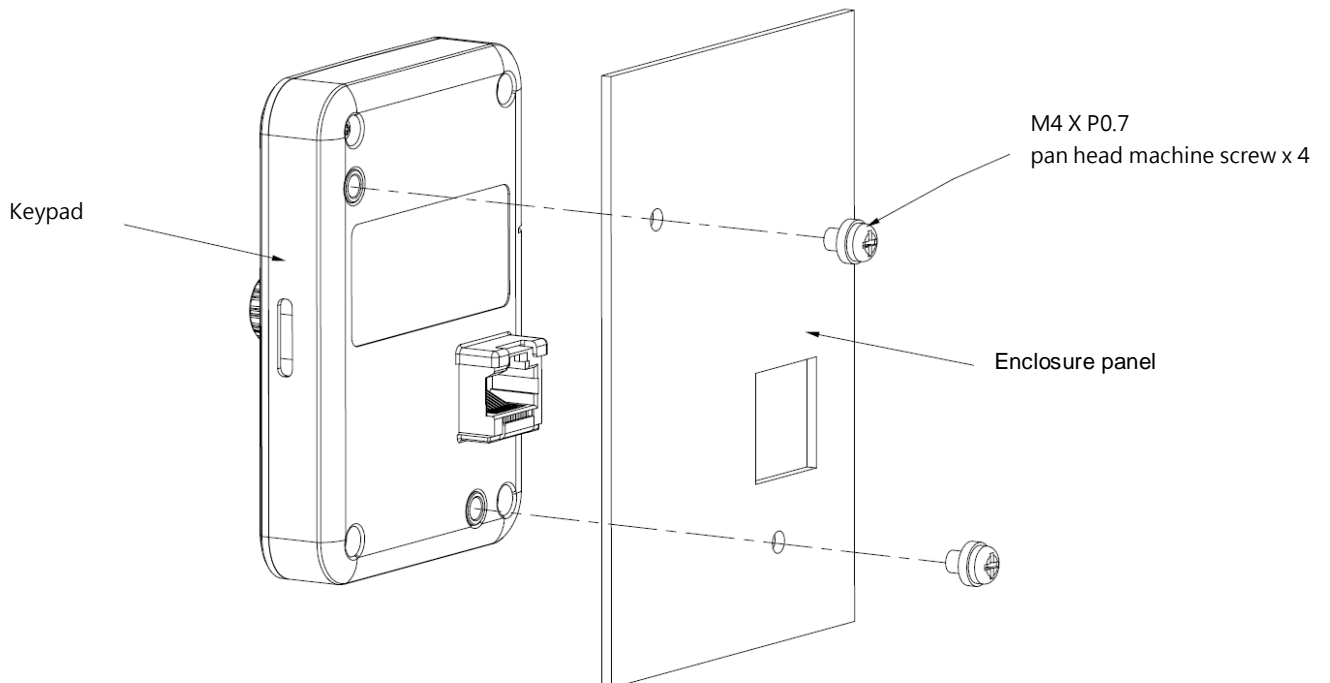

3.5.2.2 External/Face-Mount (>7.5kW models)

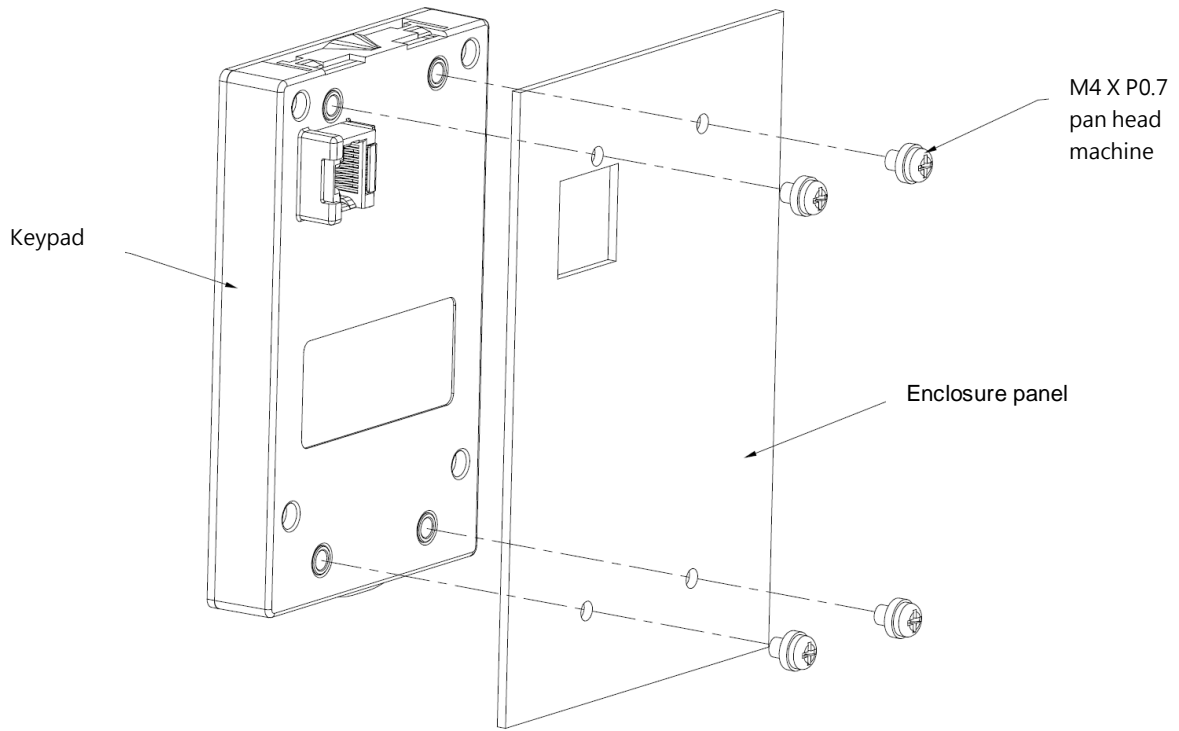

3.5.2.3 Panel Cut-Out Dimensions (<5.5kW models)

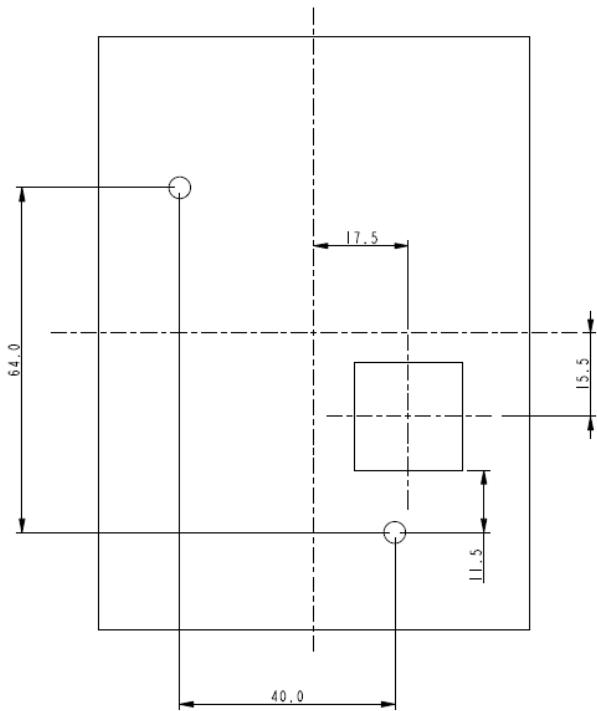

3.5.2.4 Panel Cut-Out Dimensions (>7.5kW models)

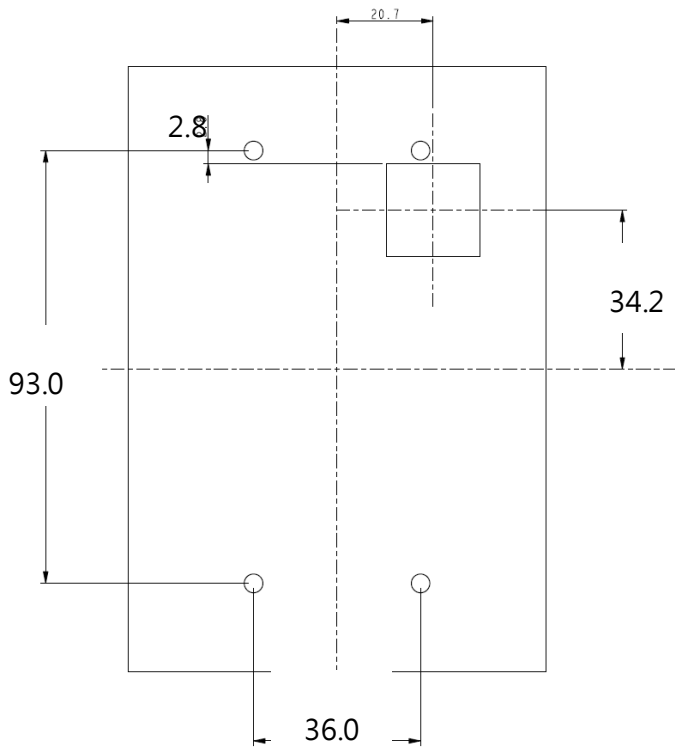

Chapter 4 | Wiring

4.1 Wiring Safety

Danger

- Turn off all the power to the equipment before wiring. Wiring during power on could cause electrical shocks to personnel.
- Allow only qualified personnel for installation, wiring, repairing and parts replacement.
- Capacitors in the drive may still be charged for a short time after shutting off the power. Wait for the amount of time specified on the drive before any maintenance.
- Never touch input or output power cables. Do not connect any circuit to drive enclosure.

Warning

- Properly connect the motor ground terminal. Contacts between the motor ground terminal and motor enclosure could cause electrical shocks or a fire.
- Ensure terminal screws are all tightened. Loose connection to the main circuit could cause overheat or a fire.
- Verify if the rated voltage of the drive matches the voltage of the incoming power supply before applying power.
- Perform all wiring as specified in the wiring diagrams provided when installing braking options. Failure to comply could result in drive, braking components damage or a fire.
- Do not disconnect the motor from the drive while the drive is outputting voltage.
- Do not use unshielded cable for control circuit wiring. Failure to comply could cause abnormal operation of drive.
- Use shielded twisted-pair cables and connect the shield to ground terminal of the drive.
- Do not modify the drive circuits. Failure to comply could cause drive damage.
- Ensure all connections are correct after connecting the drive with other devices.
- Rubber grommets located on conduit box shall be removed and replaced with conduit hubs in the end use installation.
- Integral solid state short circuit protection does not provide branch circuit protection. Branch circuit protection must be provided in accordance with the National Electrical Code and any additional local codes” , or the equivalent

4.2 Main Circuit

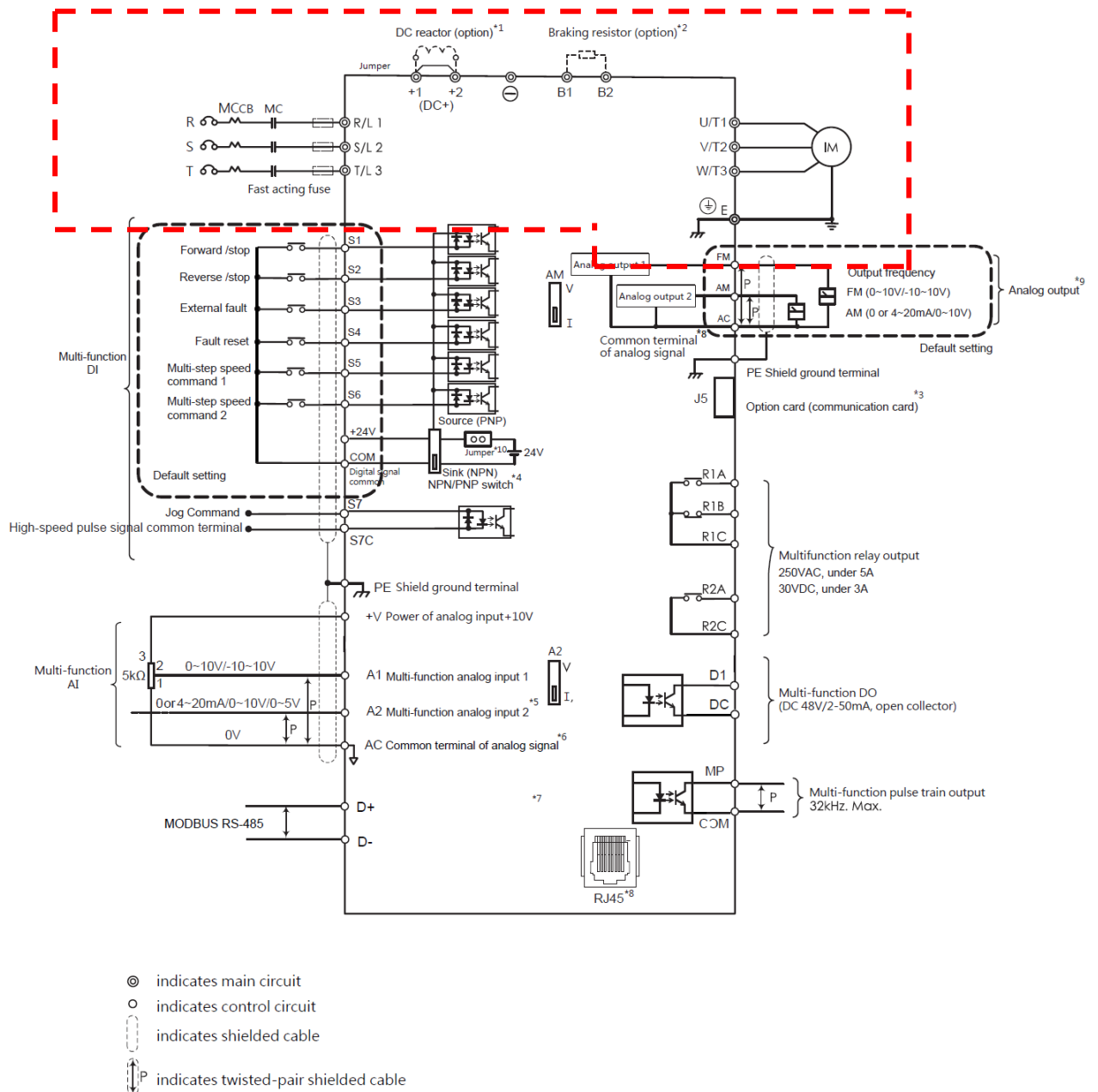

Notes:

- *1. Please remove DC+(+1/+2) jumper when installing DC reactor.
- *2. When using braking resistor, please ensure stall prevention function is off.
- *3. J5 is port of optional communication card. Please refer to user manual when installing it.
- *4. Multi-function analog input S1~S7 can be switched between Sink(NPN) or Source(PNP) mode. Default : NPN mode.
- *5. Switch A2 is used to set analog input as voltage input or current input.
- *6. AC is common terminal of analog signal (Analog Common).
- *7. Pulse input and digital inputs share the same terminal (5.5kW or less shared S4,7.5kW more common S7).
- *8. RJ45 is the communication port of RS-485.
- *9. Analog output is used to connect frequency meter, current meter, voltage meter and power meter.

4.2.1 Main Circuit Terminal

Frame 1、2

EVO680043S1D5E20、EVO680043S2D2E20、EVO680043S3D7E20、EVO680043S5D5E20

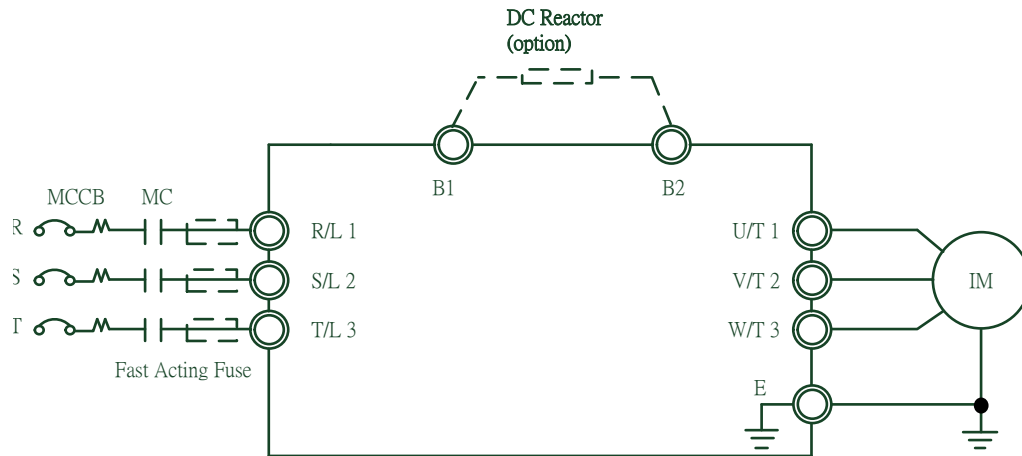

Frame 3

EVO680043S7D5E20、EVO680043S011E20

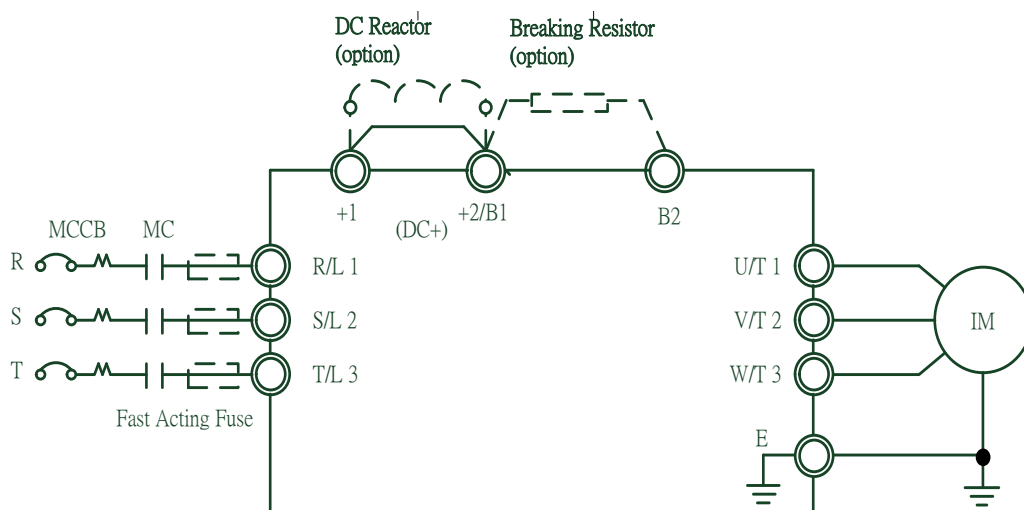

Table 4.2.1 Main Circuit Terminal

Table 4.2.1 Main Circuit Terminals

Terminal Name	Terminal Description
R/L1, S/L2, T/L3	Power input terminal
U/T1, V/T2, W/T3	Power output terminal
+1, +2 (DC+)	DC reactor terminal. Please remove the jumper before installation
B1, B2	Braking resistor terminal. Select option as per the specifications. (Please refer to Chapter 7.1)
E	Ground terminal

4.2.2 Main Circuit Wiring

4.2.2.1 Power Input Terminal

- Install a molded case circuit breaker (MCCB) between three phase AC input power and main circuit terminals R/L1, S/L2 and T/L3. A magnetic contactor (MC) in series connection is also suggested so as to shut off the power by drive protection functions. Install a R-C varistor on both ends of the MC.
- Ensure main circuit terminal screws are tightened to avoid vibration loosening the screws which could cause electric sparks.

4.2.2.2 Power Output Terminal

- When connecting a noise filter at AC drive output terminals U/T1, V/T2 and W/T3, always use an inductive L-filter. Do not install any power capacitor, L-C or R-C filter.
- Connect AC drive output terminals U/T1, V/T2 and W/T3 to motor input terminals U, V and W respectively. Ensure the motor and drive terminals are in same phase sequence or the motor will rotate reversely.
- Do not connect power cable to output terminals of the drive. Failure to comply could cause drive damage and a fire.

4.2.2.3 DC Reactor and Braking Resistor Terminal:

- The terminal is to connect a DC reactor so as to improve power factor. The drive is

shipped from the factory with a short-circuit jumper. Remove the jumper before connecting a DC reactor.

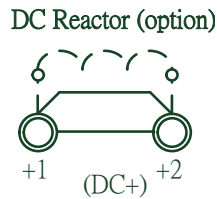

- If the drive is used in a high-frequency or heavy duty application which requires frequent braking or shorter deceleration time, install an optional braking resistor to increase the braking torque.

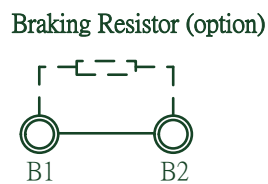

- Please refer to the wiring diagram when installing braking options.

4.2.2.4 Ground Terminal

- Use grounding cables of dimensions regulated by electrical equipment standard. Shrink wiring distance to prevent leakage current resulting unstable electrical potential at the terminal distant from grounding terminal.
- Do not use share the same grounding cable with welding machines or any device requiring large current. Failure to comply could cause drive or equipment malfunction.
- Do not wind the grounding cable when multiple drives are installed. Failure to comply could cause drive or equipment malfunction.
- Ensure the neutral of the input side and drive terminal " \oplus " are grounded according to the local electrician regulations. TN and TT system are suggested for the drive primary side.

4.2.2.5 Jumper

- EVO8000 complies with the European LVD standard EN 61800-5-1 (2007) reducing the current leakage to below 10mA DC under testing condition regulated by IEC 60990 (1999).
- Follow the instructions below to remove the jumper if an even lower current leakage to a even lower level.

- Removing the jumper may increase the signal interference.

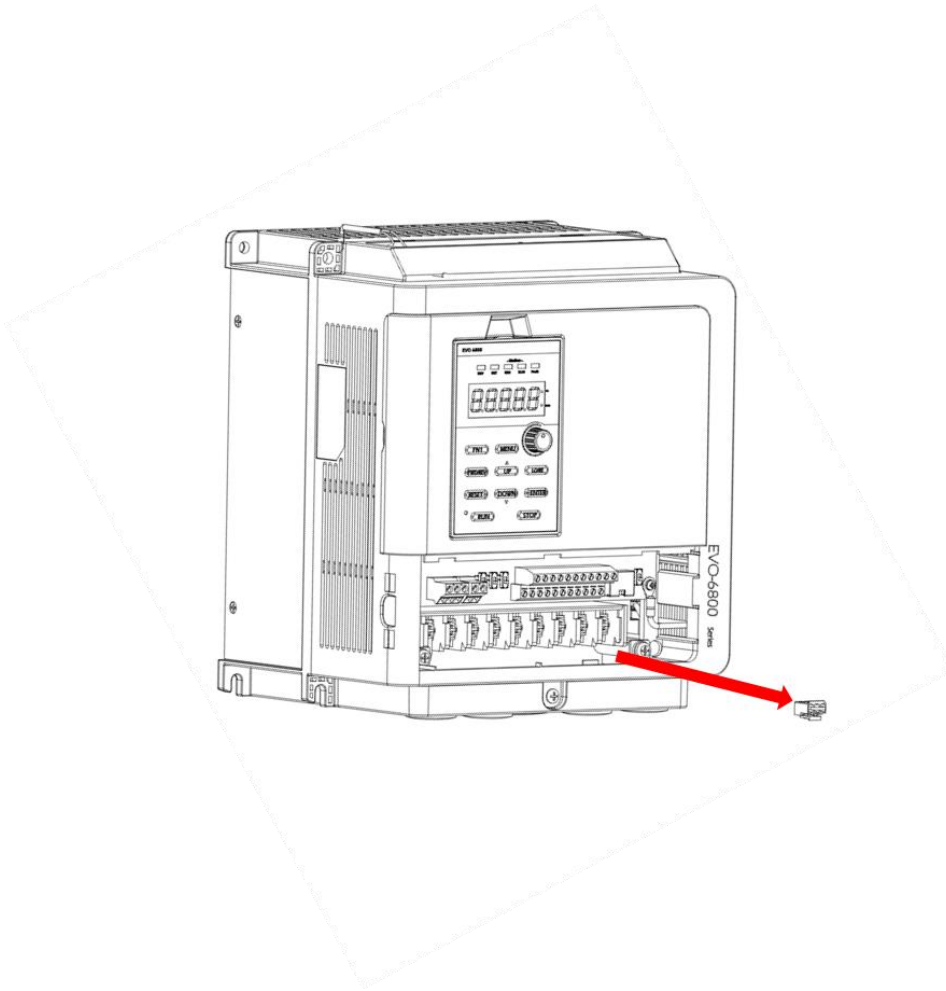

4.2.2.6 Ring Terminal

- Main circuit terminal should be used with crimp ring terminal wiring .
- Please refer to the diagram about ring terminal size, where the 8 AWG and 10 AWG bare recommend using W size must be less than 10.5 mm, d2 size must be greater than 5.0
- Ring terminal shall be insulated cover of the terminal block wiring, which can form a reference KST RVBS8-5 & KST RVB5-5 or similar size ring terminals to facilitate wiring and other operations

Diameter	Terminal Type	Terminal Specifications							
		W	d2	d1	D	F	E	L	T
AWG 8	RVBS8-5	8.8	5.3	4.5	8.5	10.5	16.7	31.6	1.2
AWG 10	RVB5-5	9.5	5.3	3.4	6.4	8.3	13	26	1

4.2.3 Main Circuit Cable Size and Tightening Torque

Select the cables and crimp terminals according to Table 4.2.2.

1. The recommended cables are 600 V vinyl-sheathed cables which have continuous temperature tolerance up to 75°C with ambient temperature tolerance up to 40 °C, wiring distance up to 100 meters and conditions suitable for on Normal Duty mode.
2. Terminal +1, +2, B1 and B2 are only for connecting DC reactor and braking resistor options. Do not connect it to other devices.
3. Consider the amount of voltage drop when selecting cable sizes. Increase the cable size when the voltage drop exceeds 2% of the motor rated voltage. The amount of voltage drop can be calculated using the following formula:

$$\text{Line drop voltage (V)} = 3 \times \text{cable resistance } (\Omega/\text{km}) \times \text{cable length (m)} \times \text{current (A)} \times 10^{-3}$$

Table 4.2.2 Cable Size and Tightening Torque (Three-phase 400 V)

Drive Rating	Terminal	Asia		USA		Europe & China		Terminal Screw Thread	Tightening Torque Nm (lb.in.)
		Suggested Cable Size mm2	Applicable Cable Size mm2	Suggested Cable Size AWG, kcmil	Applicable Cable Size AWG, kcmil	Suggested Cable Size mm2	Applicable Cable Size mm2		
1.5kW ~ 2.2kW	B1,B2,-,R/L1,S/L2,T /L3, U/T1,V/T2,W/T3	1.3	1.3~ 3.3	16	16 ~ 12	1.3	1.3~ 3.3	M4	1.36

Drive Rating	Terminal	Asia		USA		Europe & China		Terminal Screw Thread	Tightening Torque Nm (lb.in.)
		Suggested Cable Size mm2	Applicable Cable Size mm2	Suggested Cable Size AWG, kcmil	Applicable Cable Size AWG, kcmil	Suggested Cable Size mm2	Applicable Cable Size mm2		
3.7kW ~ 5.5kW	B1,B2,-,R,S,T,U,V,W	3.309	3.309~8.368	8	12 ~ 8	3.309	3.309 ~ 8.368	M4	1.8 (15.9)

Drive Rating	Terminal	Asia		USA		Europe & China		Terminal Screw Thread	Tightening Torque Nm (lb.in.)
		Suggested Cable Size mm2	Applicable Cable Size mm2	Suggested Cable Size AWG, kcmil	Applicable Cable Size AWG, kcmil	Suggested Cable Size mm2	Applicable Cable Size mm2		

7.5kW ~ 11kW	DC+1,B1/DC+2,B 2,-,R/L1,S/L2,T/L3 ,U/T1,V/T2,W/T3	8.3	5.3 ~ 8.3	8	10 ~ 8	8.3	5.3 ~ 8.3	M5	2.26 (20)
--------------------	---	-----	-----------	---	--------	-----	-----------	----	----------------

Drive Rating	Terminal	Asia		USA		Europe & China		Terminal Screw Thread	Tightening Torque Nm (lb.in.)
		Suggested Cable Size mm2	Applicable Cable Size mm2	Suggested Cable Size AWG, kcmil	Applicable Cable Size AWG, kcmil	Suggested Cable Size mm2	Applicable Cable Size mm2		
15kW ~ 18.5kW	DC+1,B1/DC+2,B 2,-,R/L1,S/L2,T/L3 ,U/T1,V/T2,W/T3	21.2	13.3 ~ 21.2	4	6 ~ 4	21.2	13.3 ~ 21.2	M6	2.45 (21.7)

Drive Rating	Terminal	Asia		USA		Europe & China		Terminal Screw Thread	Tightening Torque Nm (lb.in.)
		Suggested Cable Size mm2	Applicable Cable Size mm2	Suggested Cable Size AWG, kcmil	Applicable Cable Size AWG, kcmil	Suggested Cable Size mm2	Applicable Cable Size mm2		
22kW~ 30kW	DC+1,B1/DC+2,B 2,-,R/L1,S/L2,T/L3 ,U/T1,V/T2,W/T3	33.6	21.2~33.6	2	4~2	33.6	21.2~33.6	M8	6.37 (56.42)

Drive Rating	Terminal	Asia		USA		Europe & China		Terminal Screw Thread	Tightening Torque Nm (lb.in.)
		Suggested Cable Size mm2	Applicable Cable Size mm2	Suggested Cable Size AWG, kcmil	Applicable Cable Size AWG, kcmil	Suggested Cable Size mm2	Applicable Cable Size mm2		
37kW~ 55kW	R/L1,S/L2,T/L3,P, DC+,DC- ,U/T1,V/T2,W/T3	85	33.6~85	3/0	2~3/0	85	33.6~85	M8	7.8 (69)

Drive Rating	Terminal	Asia		USA		Europe & China		Terminal Screw Thread	Tightening Torque Nm (lb.in.)
		Suggested Cable Size mm2	Applicable Cable Size mm2	Suggested Cable Size AWG, kcmil	Applicable Cable Size AWG, kcmil	Suggested Cable Size mm2	Applicable Cable Size mm2		
75kW~ 110kW	R/L1,S/L2,T/L3,P, DC+,DC- ,U/T1,V/T2,W/T3	177	107.2~177	350MCM	4/0~350M CM	177	107.2~177	M8	7.8 (69)

4.3 Control Circuit

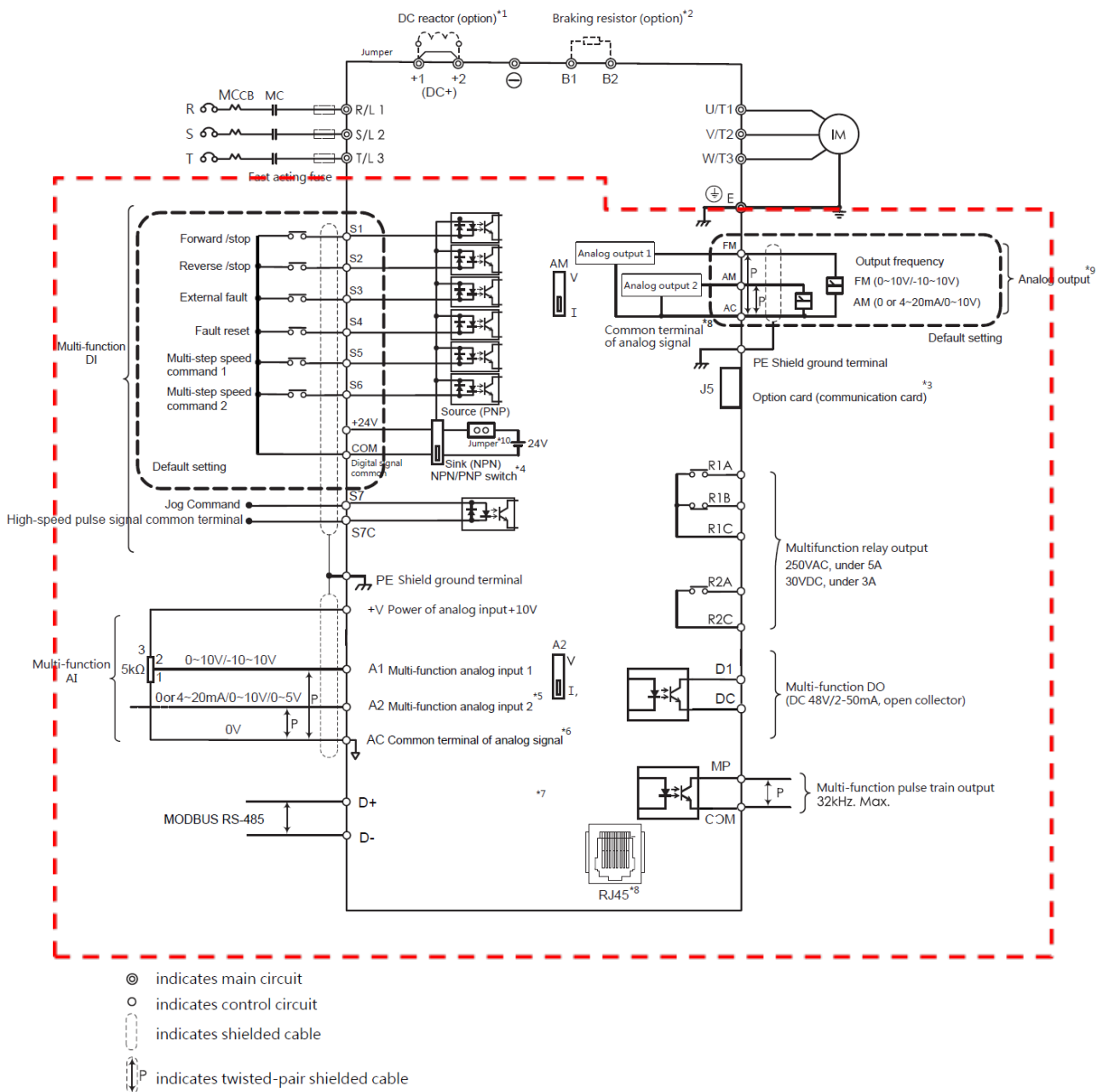

Notes:

- *1. Please remove DC+(+1/+2) jumper when installing DC reactor.
- *2. When using braking resistor, please ensure stall prevention function is off.
- *3. J5 is port of optional communication card. Please refer to user manual when installing it.
- *4. Multi-function analog input S1~S7 can be switched between Sink(NPN) or Source(PNP) mode. Default : NPN mode.
- *5. Switch A2 is used to set analog input as voltage input or current input.
- *6. AC is common terminal of analog signal (Analog Common).
- *7. Pulse input and digital inputs share the same terminal (5.5kW or less shared S4,7.5kW more common S7).
- *8. RJ45 is the communication port of RS-485.
- *9. Analog output is used to connect frequency meter, current meter, voltage meter and power meter.

4.3.1 Control Circuit Terminals

4.3.1.1 Control circuit input and output terminal (<5.5kW (more) models)

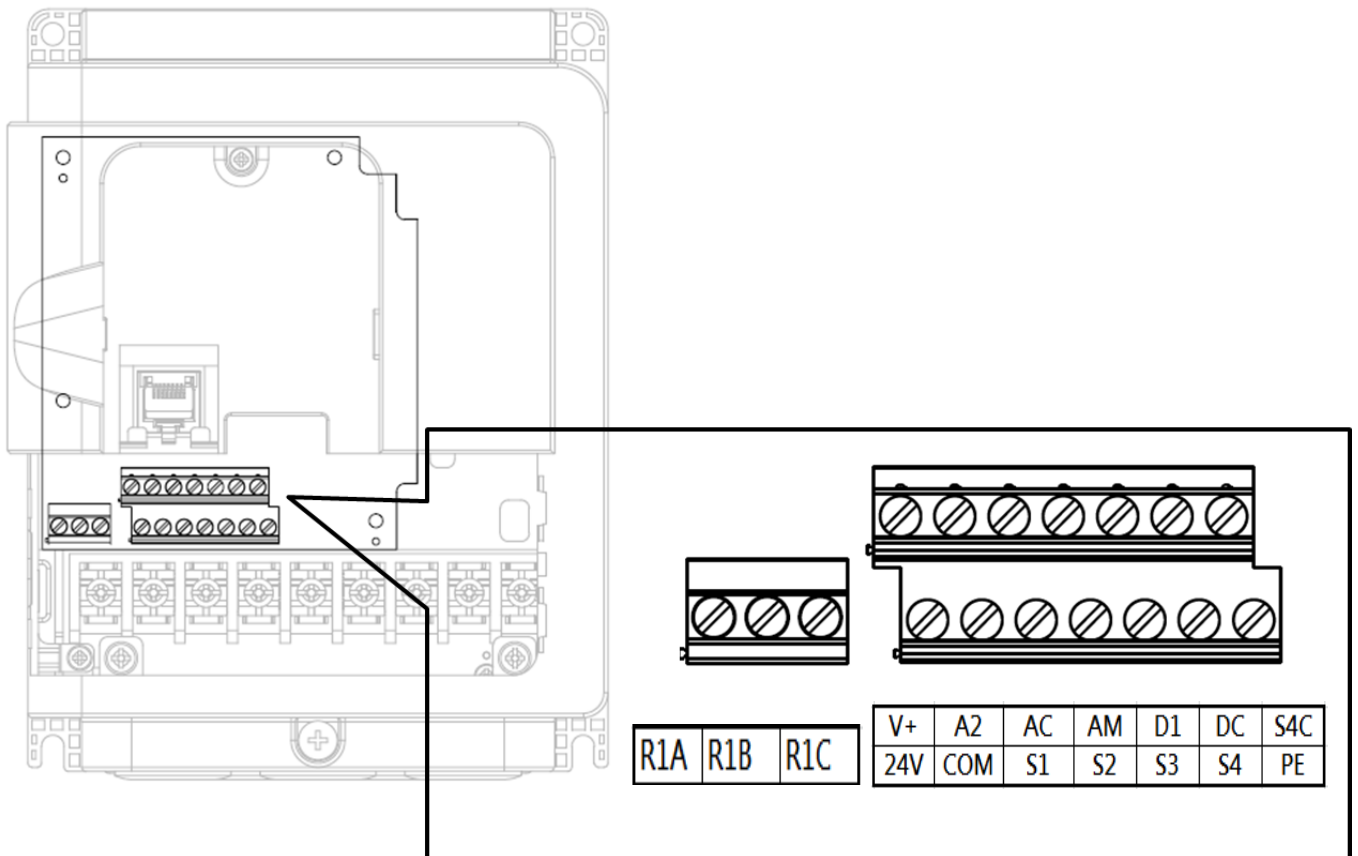

Table 4.3.1.1 Control Circuit Input Terminal

Terminal Type	Terminal Code	Terminal Name	Terminal Description
Multi-Function Digital Inputs	S1	Digital input terminal 1 (forward/stop)	Photocoupler, 24 V / 8 mA.
	S2	Digital input terminal 2 (reverse/stop)	Use Sink / Source switch to select multi-function digital input type. The default is Sink mode.
	S3	Digital input terminal 3 (external fault signal 1)	
	S4	Digital input terminal 4 (Jog command)	In addition to the characteristic S1 ~ S3, but also for the high-speed pulse input channel. Maximum input frequency: 50KHz High voltage: 10 ~ 24V Low voltage: 0 ~ 0.5V For digital inputs, switch Sink /

			Source mode must be external connection
	S4C	High-speed pulse signal common terminal	
Multi-Function Analog Inputs	+V	Auxiliary power terminal +10V	Analog input power+10V / 20mA
	A2	Analog input terminal 1 (auxiliary frequency command)	Voltage or current input (Selectable). 0 or 4 to 20mA, 0 to 10V
	PE	Ground terminal	The ground terminal for control signals to avoid interference. Use shielded cables only.
	AC	Common terminal for analog signals	
	COM	Digital control signal common terminal	
	24V	+24V auxiliary power terminal for analog input	Digital control signal power + 24V / 50mA

Table 4.3.1.2 Control Circuit Output Terminals

Terminal Type	Terminal Code	Terminal Name	Terminal Description
Multi-Function Relay Output	R1A	Relay 1 normal open	Relay output DC 30 V, 3 A AC 250 V, 5 A
	R1B	Relay 1 normal closed	
	R1C	Relay 1 common	
Multi-Function Photocoupler Output	D1	Photocoupler Output terminal 1	Photocoupler Output 30 V, 2 to 15 mA
	DC	Digital Output terminal	
	AM	Multi-function analog output terminal (output current)	Voltage or current output (Selectable) 0 or 4 to 20mA, 0 to 10V
	AC	Analog common terminal	

4.3.1.2 <5.5kW models, NPN and PNP wiring

NPN models (S1~S3)

Internal power supply

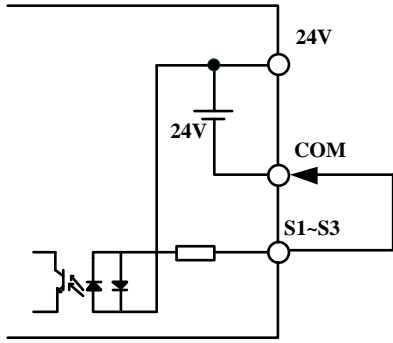

External power supply (Remove the J13 short circuit PIN)

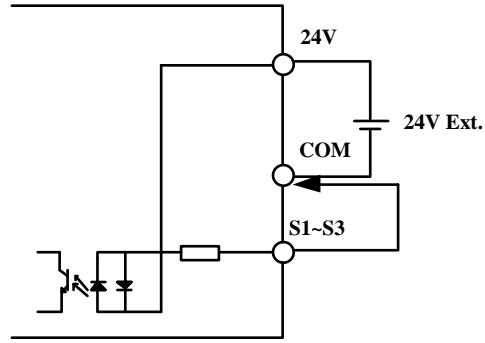

PNP models (S1~S3)

Internal power supply

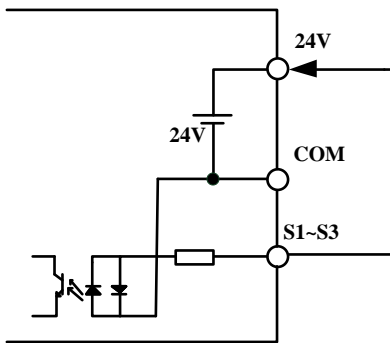

External power supply (Remove the J13 short circuit PIN)

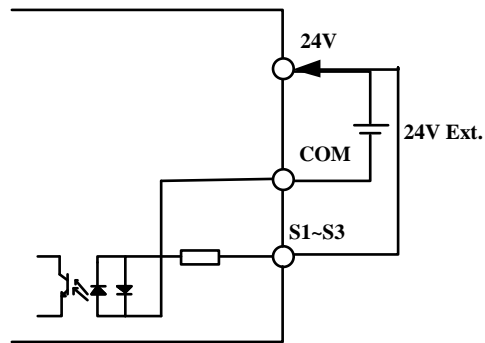

Due to multi-function input terminal S4 common pulse function, wiring and S1 ~ S3 different way, way below refer to the wiring

NPN models (S4)

Internal power supply

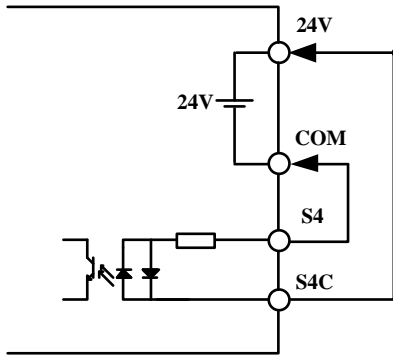

External power supply (Remove the J13 short circuit PIN)

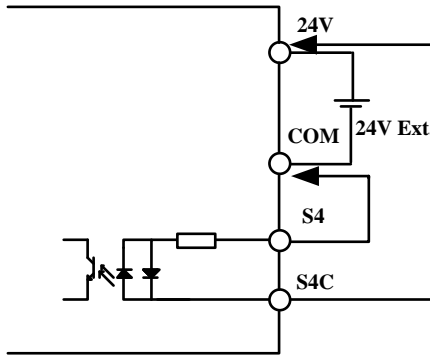

PNP models (S4)

Internal power supply

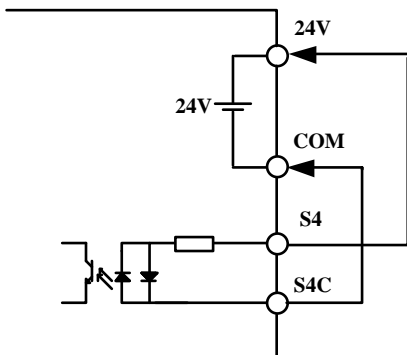

External power supply (Remove the J13 short circuit PIN)

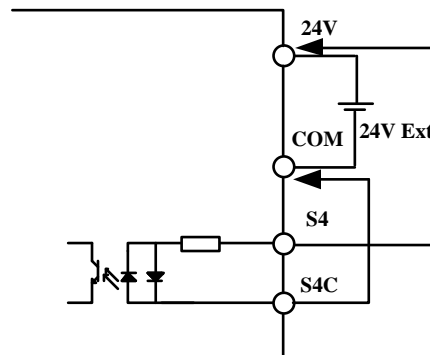

4.3.1.3 Control circuit input and output terminal (>7.5kW (more) models)

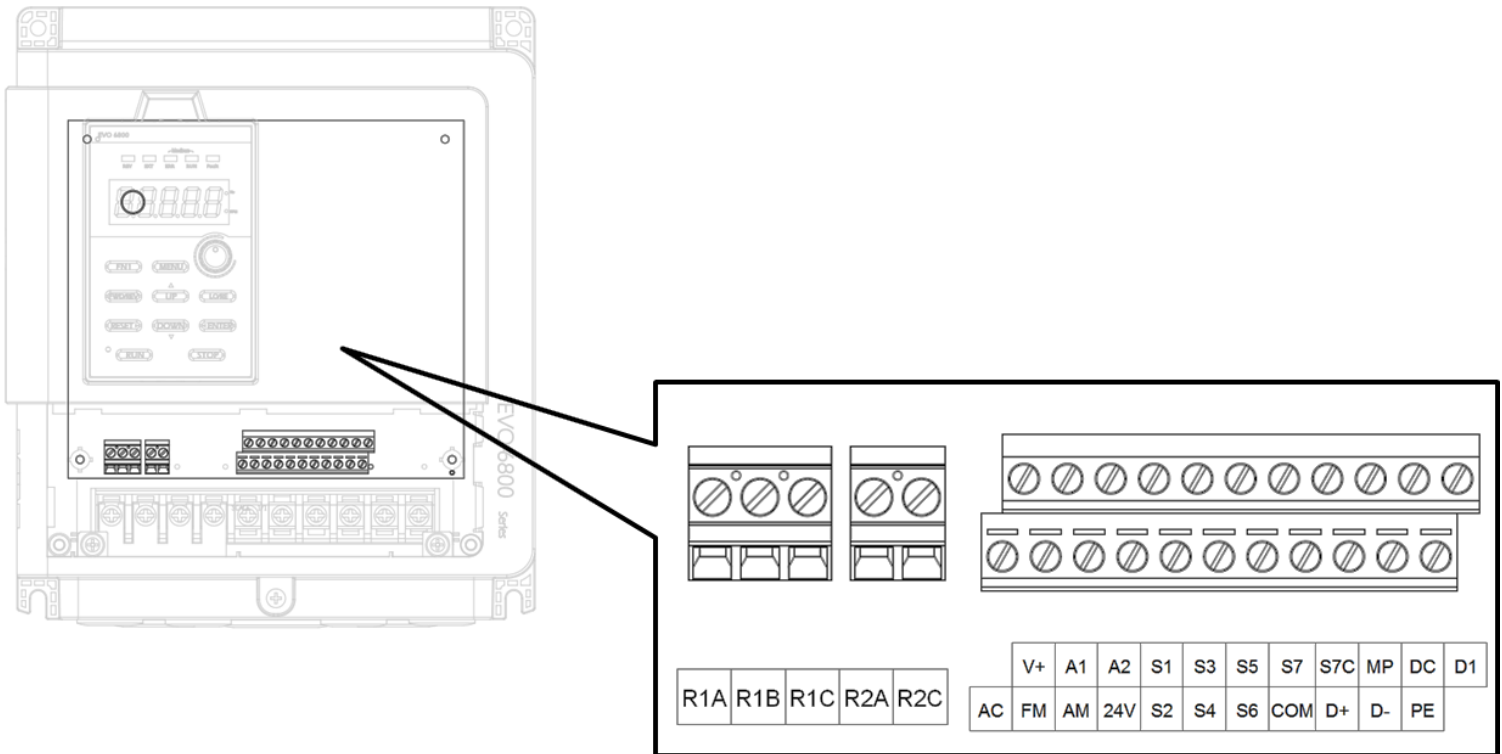

Table 4.3.1.3 Control Circuit Input Terminal

Terminal Type	Terminal Code	Terminal Name	Terminal Description
Multi-Function Digital Inputs	S1	Digital input terminal 1 (forward/stop)	Photocoupler, 24 V, 8 mA. Use NPN/PNP switch to select multi-function digital input type. The default is NPN mode.
	S2	Digital input terminal 2 (reverse/stop)	
	S3	Digital input terminal 3 (external fault 1)	
	S4	Digital input terminal 4 (fault reset)	
	S5	Digital input terminal 5 (multi-step speed 1)	
	S6	Digital input terminal 6 (multi-step speed 2)	
	S7	Digital input terminal 7 (Jog command)	In addition to the characteristic S1 ~ S6, but also for the high-speed pulse input channel. Maximum input frequency: 50KHz

			High voltage: 10 ~ 24V Low voltage: 0 ~ 0.5V For digital inputs, switch Sink / Source mode must be external connection
	S7C	High-speed pulse signal common terminal	
	COM	Digital control signal common terminal	
Multi-Function Analog Inputs	+V	Auxiliary power terminal +10V	Analog input power+10V
	A1	Analog input terminal 1 (main frequency command)	Voltage input 0 to 10V / -10V to +10V
	A2	Analog input terminal 2 (auxiliary frequency command)	Voltage or current input (Selectable). 0 or 4 to 20mA, 0 to 10V, 0 to 5V
	PE	Ground terminal	The ground terminal for control signals to avoid interference. Use shielded cables only.
	24V	+24V auxiliary power terminal for analog input	Digital control signal power + 24V (INT port selection by short-circuiting) INT: short circuit, internal offer + 24V / 200mA: open, externally supplied + 24V

Table 4.3.1.2 Control Circuit Output Terminals

Terminal Type	Terminal Code	Terminal Name	Terminal Description
Multi-Function Relay Output	R1A	Relay 1 normal open	Relay output DC 30 V, 3 A AC 250 V, 5 A
	R1B	Relay 1 normal closed	
	R1C	Relay 1 common	
	R2A	Relay 2 normal open	
	R2C	Relay 2 normal closed	
Multi-Function Photocoupler Output	D1	Photocoupler Output terminal 1 (zero speed)	Photocoupler Output 48 V, 2 to 50 mA
	D2	Photocoupler Output terminal 2 (speed agree)	
	D+	RS485 communication terminal, standard RS485 interface, use twisted pair or shielded wire	
	D-		
Multi-Function Analog Output	FM	Programmable analog output terminal (output frequency)	Voltage Output 0 to 10V, -10 to +10V
	AM	Multi-function analog output terminal (output current)	Voltage or current output (Selectable) 0 or 4 to 20mA, 0 to 10V

	AC	Analog common terminal	
Multi-Function Pulse Train Output	MP	Multi-function pulse train output (output frequency)	32KHz Max

<1> Do not assign frequent switching functions such as ON/OFF to terminals R1 and R2, which may shorten the relay terminal life.

4.3.1.4 >7.5kW models, NPN and PNP wiring

Internal power supply

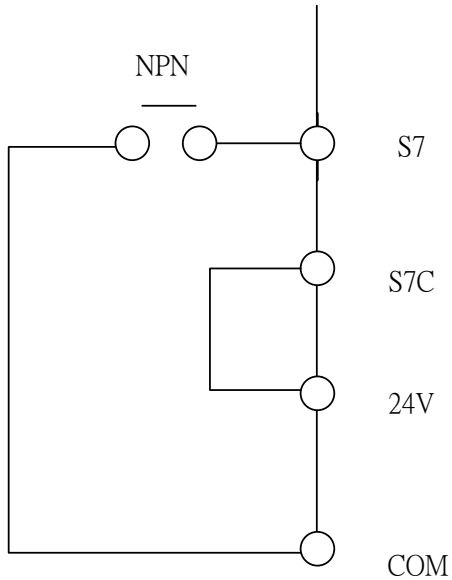

External power supply (Remove the J13 short circuit PIN)

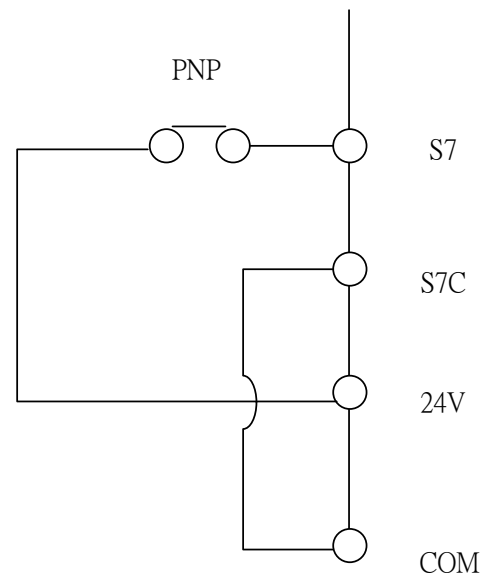

4.3.2 Control Circuit Cable Size and Tightening Torque

Select the cable according to Table 4.3.3.1. Use crimp ferrules on the cable ends for simpler and more reliable wiring.

Table 4.3.3.1 Cable Size and Tightening Torque

Terminal	Screw Size	Tightening Torque Nm (lb.in.)	Bare Cable		Ferrule-Type Terminal		Cable Type
			Applicable Size mm ² (AWG)	Suggested Size mm ² (AWG)	Applicable Size mm ² (AWG)	Suggested Size mm ² (AWG)	
10V, A2, AC, AM, D1, DC, COM, 24V, SC, S1, S2, S3, S4, PE	M2.5	0.4 (3.52)	0.13 ~ 2.08 (26 ~ 14)	0.13 (26)	0.41 ~ 1 (17 ~ 21)	0.41 (17)	Shielded cable, etc.
R1A, R1B, R1C	M2.5	0.57 (5)	0.13 ~ 3.31 (26 ~ 12)	0.13 (26)	3.31 ~ 5.26 (12 ~ 10)	3.31 (12)	Shielded cable, etc.

Table 4.3.2.2 Cable Size and Tightening Torque (>7.5kW models)

Terminal	Screw Size	Tightening Torque Nm (lb.in.)	Bare Cable		Ferrule-Type Terminal		Cable Type
			Applicable Size mm ² (AWG)	Suggested Size mm ² (AWG)	Applicable Size mm ² (AWG)	Suggested Size mm ² (AWG)	
AC,V+,FM,A1,AM,A2,24V,S1,S2,S3,S4,S5,S6,S7,COM,S7C,D+,MP,D-DC,PE,D1	M2.5	0.59 (5.2)	0.13 ~ 1.31 (26 ~ 16)	0.13 (26)	0.13 ~ 0.33 (26 ~ 22)	0.13 (26)	Shielded cable, etc.
R1A,R1B,R1C,R2A,R2C	M2.5	0.59 (5.2)	0.2 ~ 3.31 (24 ~ 12)	0.2 (24)	0.2 ~ 0.33 (24 ~ 22)	0.2 (24)	Shielded cable, etc.

4.3.4 Ferrule-Type Terminals

Always use ferrule-type terminals with insulated sleeves. Refer to Table 4.3.3.2. for dimensions. In addition, crimping tool CRIMPFOX ZA-3 manufactured by Phoenix Contact is recommended.

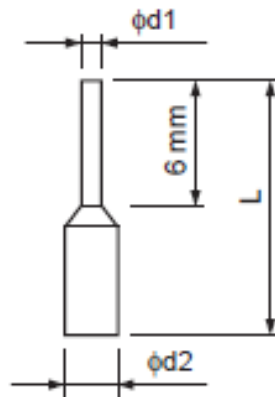

Table 4.3.3.2 Ferrule-Type Terminal Models and Sizes

Cable Size mm ² (AWG)	Type	L (mm)	d1 (mm)	d2 (mm)	Manufacturer
0.25 (24)	AI 0.25-6YE	10.5	0.8	2	Phoenix Contact
0.34 (22)	AI 0.34-6TQ	10.5	0.8	2	Phoenix Contact
0.5 (20)	AI 0.56-WH	14	1.1	2.5	Phoenix Contact

4.4 I/O Connections

4.4.1 NPN and PNP Mode Selection

Use Sink/Source DIP switch on the control board to set NPN/PNP mode for multi-function digital inputs S1 to S7. (Default: NPN mode)

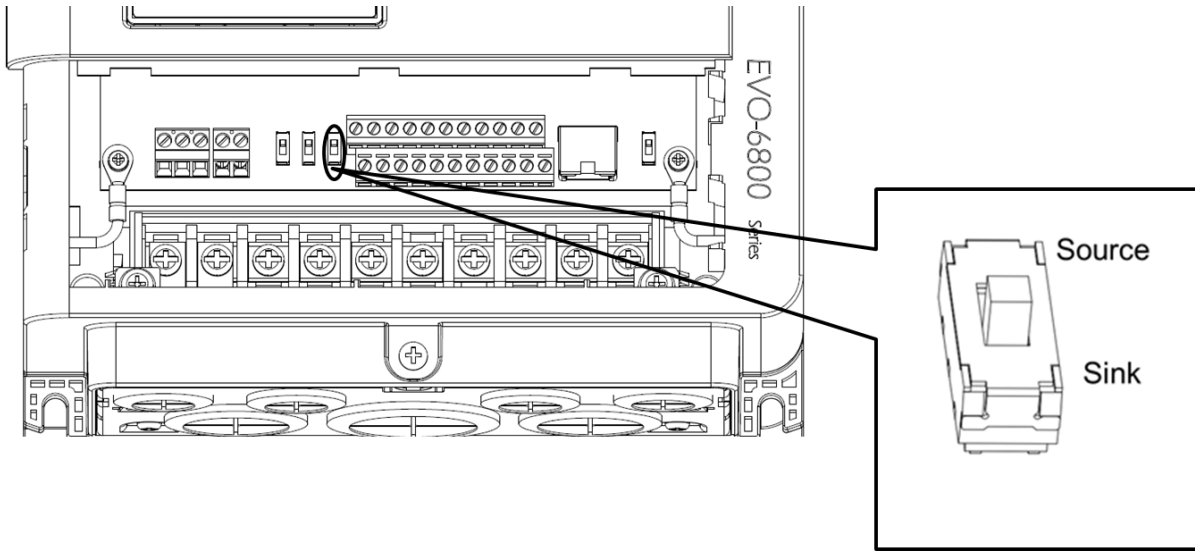

Figure 4.4.1.1 $< 5.5\text{KW}$ Sink/Source DIP Switch

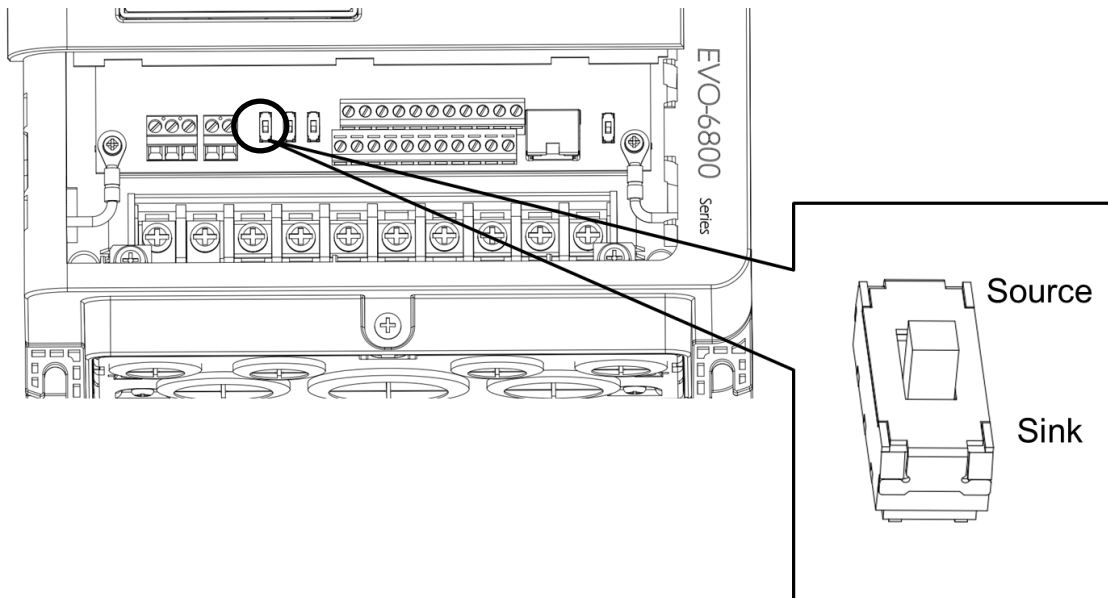

Figure 4.4.1.2 $> 7.5\text{KW}$ Sink/Source DIP Switch

4.4.2 Terminal A2 Voltage/Current Input Selection

Select voltage or current input at terminal A2

- To select current as the input type, set DIP switch A2 to I and set parameter E3-06 to 0 (0 to 20 mA) or 1 (4 to 20 mA).
- To select voltage as the input type, set DIP switch A2 to V and set parameter E3-06 to 2 (0 to 10 V) or 3 (0 to 5 V).

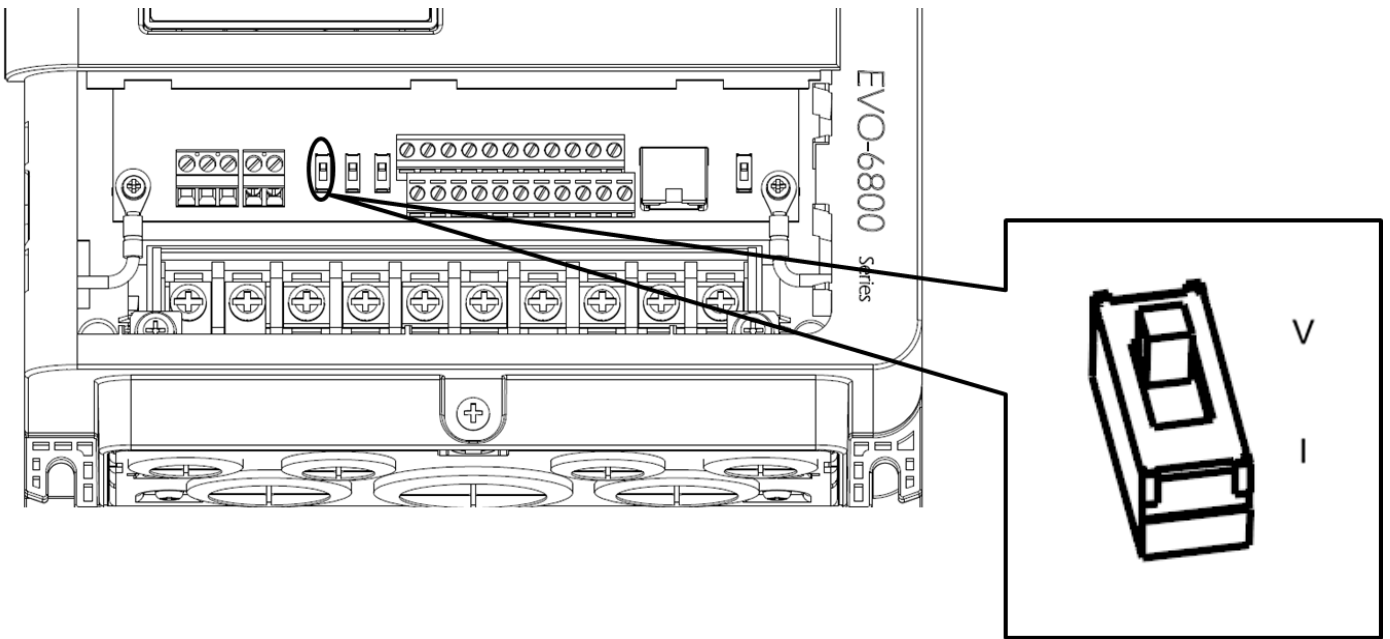

Figure 4.4.2 .1 <5.5KW DIP Switch A2

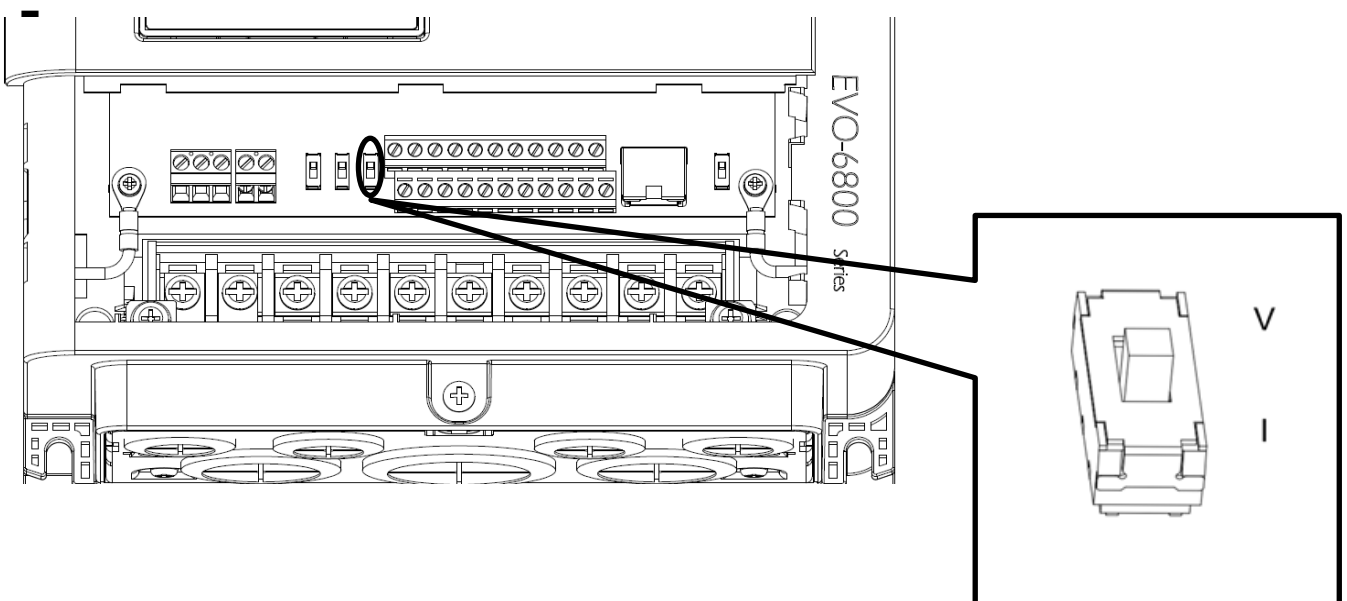

Figure 4.4.2.2 >7.5KW DIP Switch A2

Table 4.4.1 DIP Switch A2 Settings (Terminal A2)

Setting	Description
V	Voltage input (0 to 10 V or 0 to 5 V)
I	Current input (4 to 20 mA or 0 to 20 mA) (default)

Table 4.4.2 Parameter E3-06

No.	Parameter Name	Description	Setting Range	Default
E3-06	Terminal A2 Signal Level Selection	Selects the signal level for terminal A2. 0: 0 ~ 20 mA 1: 4 ~ 20 mA 2: 0 ~ 10 V 3: 0 ~ 5 V	0, 1, 2, 3	1

4.4.3 Terminal AM Voltage/Current Output Selection

Select voltage or current output type for terminal AM

- To select voltage as the output type, set DIP switch AM to V and set parameter E4-04 to 0 (0 to 10 V).
- To select current as the output type, set DIP switch AM to I and set parameter E4-04 to 1 (0 to 20 mA) or 2 (4 to 20 mA).

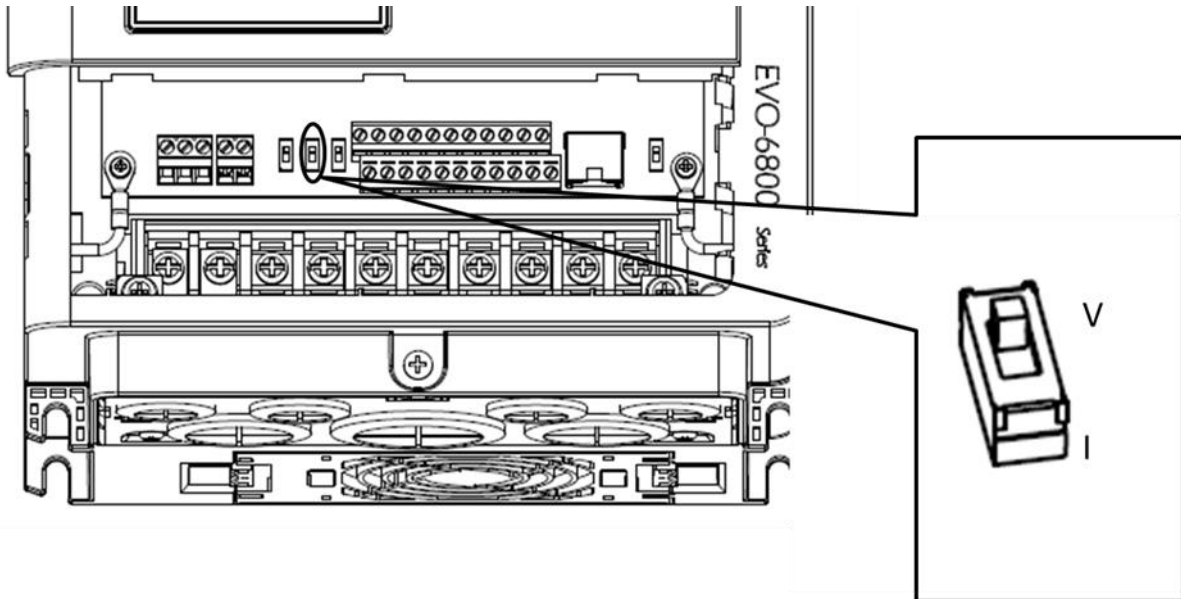

Figure 4.4.3 DIP Switch AM

Table 4.4.3 DIP Switch AM Setting (Terminal AM)

Setting	Description
V	Voltage output (0 to 10 V)
I	Current output (4 to 20 mA or 0 to 20 mA) (default)

Table 4.4.4 Parameter 4-04

No	Parameter Name	Description	Setting Range	Default
E4-04	Terminal AM Signal Level Selection	Selects the signal level for terminal AM 0 : 0 to 10 V 1 : 0 to 20 mA 2 : 4 to 20 mA	0, 1, 2	2

4.4.4 RS-485 Communication Termination ON / OFF Switch(>7.5KW)

The default of termination resistor for RS-485 communication is OFF. Switch it to ON when the drive is the last in a series of slave drives. Set this termination resistor on DIP switch RS485 illustrated in Figure 4.4.4.

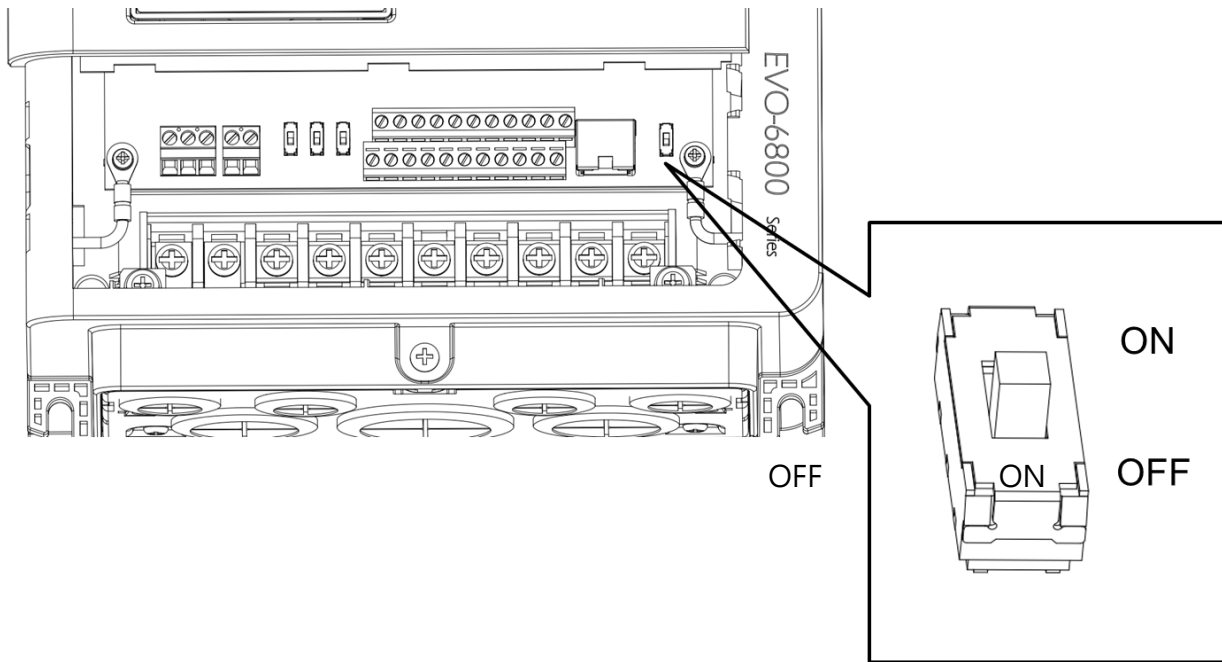

Figure 4.4.4 DIP Switch RS-485 Termination Resistor

4.5 Connection to PC

The drive is equipped with a RJ45 port. The drive can connect to a PC through RJ45 cable to manage parameter settings using LiteOn PC software.

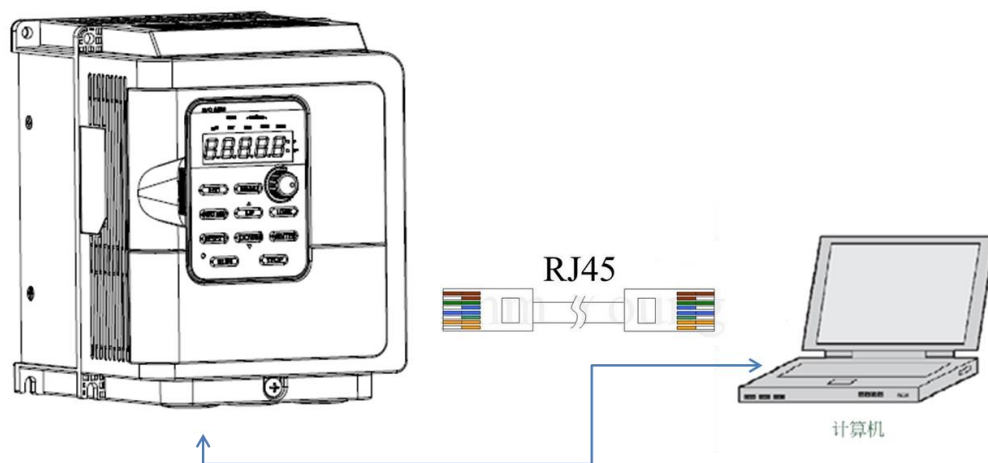

Figure 4.5 Connection to PC

4.6 Wiring Checklist

Table 4.6 Wiring Checklist

<input type="checkbox"/>	No.	Item	Page
Power Supply Voltage and Output Voltage			
<input type="checkbox"/>	1	Power supply voltage is within the voltage range of specified drive input.	
<input type="checkbox"/>	2	The motor voltage matches the drive output specifications.	
<input type="checkbox"/>	3	The drive rating matches the motor rating.	
Main Circuit Wiring			
<input type="checkbox"/>	4	An MCCB of proper specifications is connected between the drive and motor.	
<input type="checkbox"/>	5	Power cables are correctly connected to drive input terminals R/L1, S/L2 and T/L3.	
<input type="checkbox"/>	6	Motor terminals and drive terminals U/T1, V/T2 and W/T3 are in same phase sequence. (Otherwise the motor will rotate reversely)	
<input type="checkbox"/>	7	Power supply and motor power cable complies with electrician regulations.	
<input type="checkbox"/>	8	The drive is properly grounded.	
<input type="checkbox"/>	9	Drive terminal screws of the main circuit and ground are tightened.	
<input type="checkbox"/>	10	<p>An MC is installed for each motor if a single drive runs more than on motor.</p> <div data-bbox="395 1041 1241 1310" style="text-align: center;"> <p style="text-align: center;">MC1 ~ MCn Magnetic Contactor</p> </div> <p>Note: Set MC1 to MCn OFF before operating the drive. Do not switch MC1 to MCn ON or OFF during run.</p>	
<input type="checkbox"/>	11	When using a braking resistor or braking unit, an MC is installed on the drive input side and able to shut off the power to drive when overloaded.	
Control Circuit Wiring			
<input type="checkbox"/>	12	Twisted-pair cables are used for all drive control circuit wiring.	
<input type="checkbox"/>	13	Shielded cables are connected to the terminals.	
<input type="checkbox"/>	14	Options (if any) are properly installed.	
<input type="checkbox"/>	15	No wiring mistakes.	
<input type="checkbox"/>	16	Do not use a buzzer to check wiring.	
<input type="checkbox"/>	17	The control circuit terminal screws are tightened.	
<input type="checkbox"/>	18	No cable clippings or screws are left inside the drive enclosure.	
<input type="checkbox"/>	19	Control circuit wiring and main circuit wiring are separated.	

Chapter 5 | Keypad and Parameters

5.1 Keypad

Use the keypad to enter RUN and STOP commands, display data, fault, alarm and set parameters. The keypad of EVO 8000 series can be removed and connected to the drive using an extension cable. The remote keypad can be mounted on control panels with screws thread M4 X P0.7 and the screw length longer than the thickness of panel door.

5.1.1 Keys and Displays

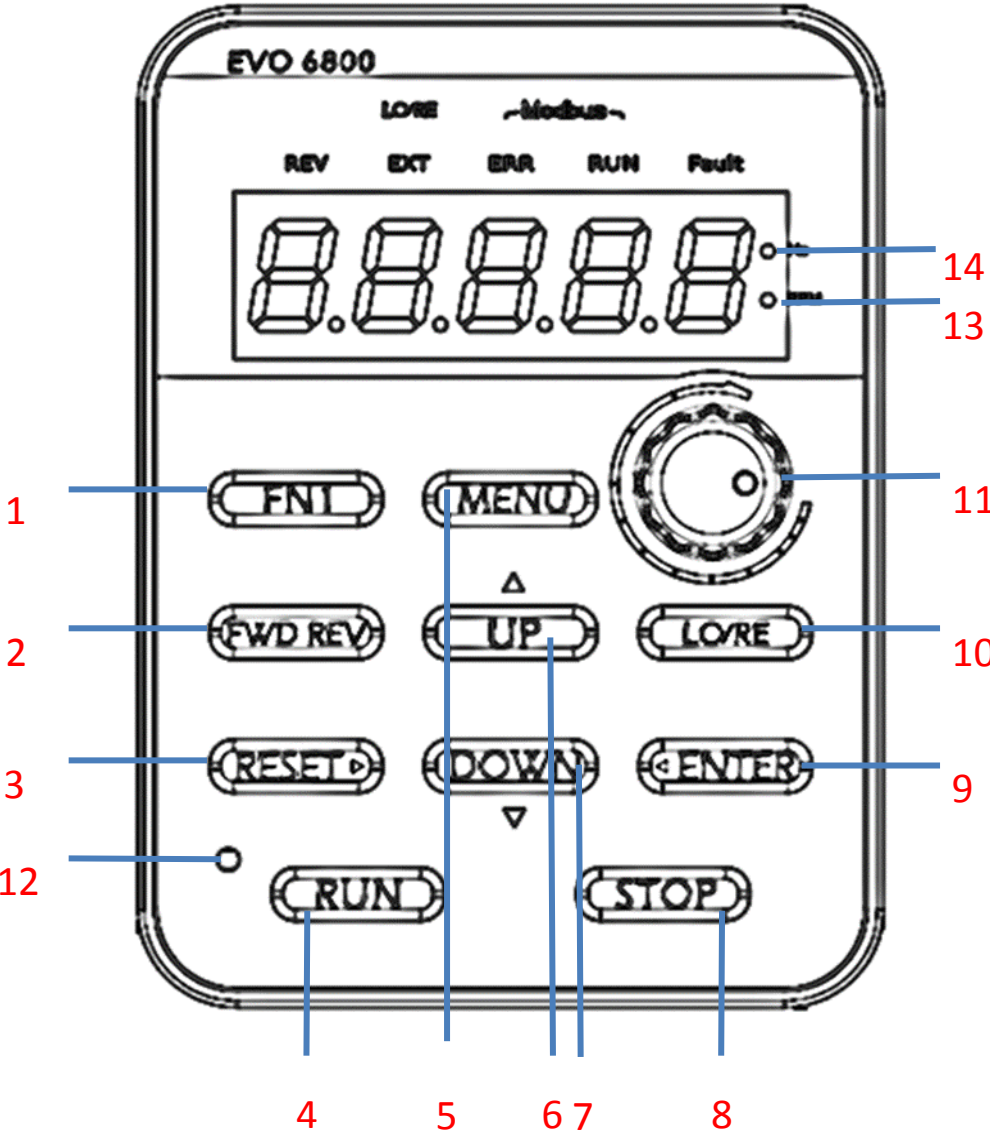









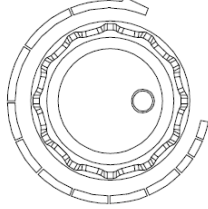
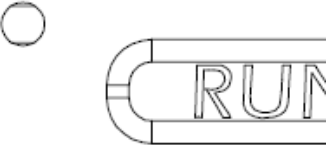
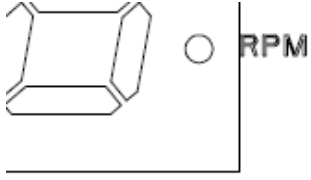
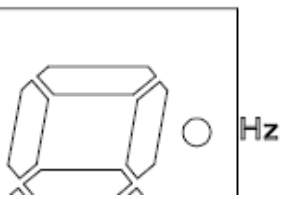

Figure 5.1.1 Keypad

Table 5.1.1 Keypad Keys and Displays

No	Button	Name	Function
1		FN1 Key	User-defined function key for Quick Setting Mode
2		FWD/REV Key	Forward/reverse selection
3		RESET Key	<ul style="list-style-type: none"> ■ Moves the cursor to the right ■ Resets the drive to clear a fault situation
4		RUN Key	Runs the drive
5		MENU Key	<ul style="list-style-type: none"> ■ Enters or exits the parameter group ■ Switches the displayed menu
6		UP/DOWN Key	Selects parameter numbers, increments and decrements setting value and frequency
7			
8		STOP Key	Stops the drive
9		ENTER Key	<ul style="list-style-type: none"> ■ Enters parameter value, parameter and setting ■ Enters parameter setting menu.

10		LO/RE Key	LOCAL、REMOTE控制选择。
11		Non-Slip Setting Dial	ENTER Key: ■ Enters parameter value, parameter and setting ■ Enters parameter setting menu. Dial: Increases or decreases parameter numbers, setting value and frequency
12		RUN Light	Refer to Table 5.1.2.2
13		RPM Light	Refer to Table 5.1.2.2
14		Hz Light	Refer to Table 5.1.2.2

5.1.2 Keypad Display

5.1.2.1 LED Display

Table 5.1.2.1 LED Display

Number /Letter	LED Display	Number /Letter	LED Display	Number /Letter	LED Display	Number /Letter	LED Display
0	0	9	9	i	ı	r	ƚ
1	1	A	A	J	ƚ	S	S
2	2	b	b	K	Nil	t	t
3	3	c	C	L	L	U	U
4	4	d	d	M	Nil	v	v
5	5	E	E	n	n	W	Nil
6	6	F	F	o	o	X	Nil
7	7	G	G	P	P	y	Nil
8	8	H	H	q	Nil	Z	Nil

5.1.2.2 LED Indication

Table 5.1.2.2 LED Indication

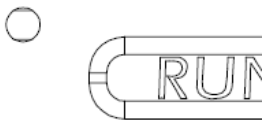
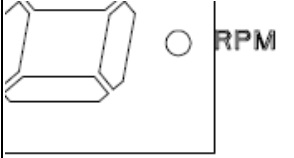
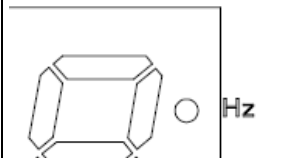
Indicator Light	Lit	Blinking	Off
	Drive in operation	<ul style="list-style-type: none"> ■ Drive in deceleration ■ Output frequency below the minimum frequency 	Drive not in operation
	Displaying output speed	Nil	Nil
	Displaying output frequency	Nil	Nil

5.1.2.3 LO/RE And EXT LED Display

	EXT	LO/RE	Lights
Local	OFF (Only Control On Keypad)	ON	Green
Remote	Off(When the source is set to Keypad operation)	OFF	OFF
	ON	OFF	Red

5.1.3 Keypad Programming

- Keypad Display Menu Structure
- Standard setting mode: Press MENU to enter or exit the parameter group. Press ENTER, MENU, UP, DOWN and RESET to monitor and edit settings.
- Quick monitoring parameters mode: FN2 function keys for using quickly most of the parameters monitored, and use the up and down keys to switch parameters want to monitor.

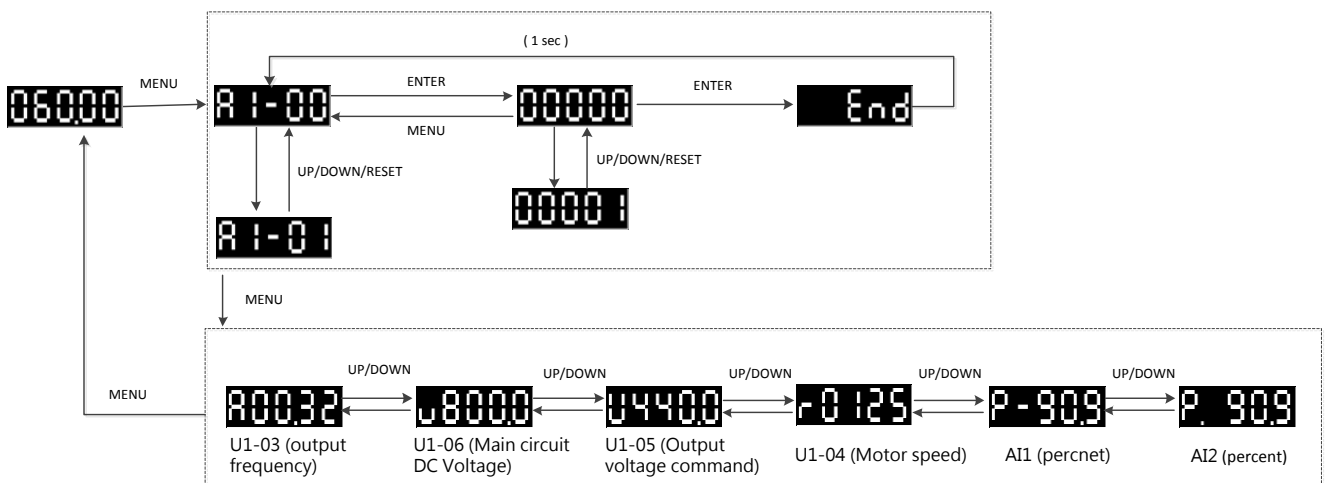

- Quick setting mode: User must assign the function to the FN1 key in advance so as to quickly set the parameter by pressing FN1 key.

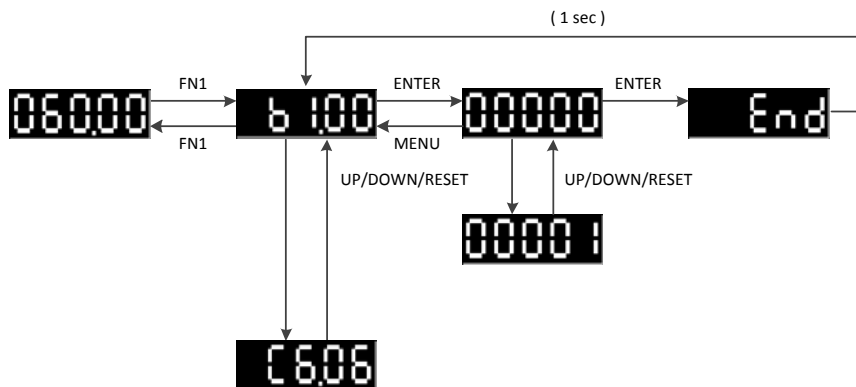

5.2 Parameter List

Parameter	Name	Description	Setting Range
Group A, Initialization			
A1: Basic Settings			
A1-01 <4>	Access Level Selection	Selects access level (edit /view) 0: View Only Access to only parameter A1-01 1: User-Defined Parameter Access Access to only parameter A1-01 and A2-00 to A2-31 2: All Parameter Access All parameters can be edited and viewed	Default: 2 Range: 0, 1, 2
A1-02	Control Method Selection	0: V/F Control 1: Senserless Voltage Vector Control	Default: 0 Min.: 0 Max.: 1
A1-03	Reset	Resets parameter settings to defaults. After resetting parameters, the value will become 0. 2538: Resets 2-Wire Sequence / 50Hz / 380V 2541: Resets 2-Wire Sequence / 50Hz / 415V 2544: Resets 2-Wire Sequence / 50Hz / 440V 2546: Resets 2-Wire Sequence / 50Hz / 460V 2638: Resets 2-Wire Sequence / 60Hz / 380V 2641: Resets 2-Wire Sequence / 60Hz / 415V 2644: Resets 2-Wire Sequence / 60Hz / 440V 2646: Resets 2-Wire Sequence / 60Hz / 460V 3538: Resets 3-Wire Sequence / 50Hz / 380V 3541: Resets 3-Wire Sequence / 50Hz / 415V 3544: Resets 3-Wire Sequence / 50Hz / 440V 3546: Resets 3-Wire Sequence / 50Hz / 460V 3638: Resets 3-Wire Sequence / 60Hz / 380V 3641: Resets 3-Wire Sequence / 60Hz / 415V 3644: Resets 3-Wire Sequence / 60Hz / 440V 3646: Resets 3-Wire Sequence / 60Hz / 460V	Default: 0 Range: 0 to 9999
A1-04	Password	Set password to parameter A1-05 and enter the password to parameter A1-04 to unlock it.	Default: 0000
A1-05	Password Setting	Parameters A1-01 to A1-03, A1-06, A2-01 to A2-32 cannot be edited until correct password is entered to A1-04	Min.: 0000 Max.: 9999
A1-06	ND/HD Selection	0: Heavy Duty (HD)	Default: 0

Parameter	Name	Description	Setting Range																																																																																																						
		1: Normal Duty (ND)	Range: 0, 1																																																																																																						
A2: User-Defined Parameters																																																																																																									
A2-00 to A2-31	User-Defined Parameters 1 to 32	<p>Selects up to 32 parameters and assigns them to parameter A2-00 to A2-31. Saved parameters can be viewed in User-Defined Parameter Access. To assign specific parameters to A2-00 to A2-31, set parameter A1-01 to 2. The saved parameters A2-00 to A2-31 can only be viewed if A1-01 is set to 1</p> <table border="1"> <thead> <tr> <th>Parameter</th> <th>Default</th> <th>Name</th> <th>Parameter</th> <th>Default</th> <th>Name</th> </tr> </thead> <tbody> <tr> <td>A2-00</td> <td>b1-00</td> <td>Frequency Command Selection</td> <td>A2-16</td> <td>E3-07</td> <td>Terminal A2 Function Selection</td> </tr> <tr> <td>A2-01</td> <td>b1-01</td> <td>Run Command Selection</td> <td>A2-17</td> <td></td> <td></td> </tr> <tr> <td>A2-02</td> <td>C1-00</td> <td>Acceleration Times</td> <td>A2-18</td> <td></td> <td></td> </tr> <tr> <td>A2-03</td> <td>C1-01</td> <td>Deceleration Times</td> <td>A2-19</td> <td></td> <td></td> </tr> <tr> <td>A2-04</td> <td>C3-00</td> <td>Torque Compensation Gain</td> <td>A2-20</td> <td></td> <td></td> </tr> <tr> <td>A2-05</td> <td>d1-02</td> <td>Maximum Output Frequency</td> <td>A2-21</td> <td></td> <td></td> </tr> <tr> <td>A2-06</td> <td>d1-03</td> <td>Maximum Voltage</td> <td>A2-22</td> <td></td> <td></td> </tr> <tr> <td>A2-07</td> <td>d1-04</td> <td>Base Frequency</td> <td>A2-23</td> <td></td> <td></td> </tr> <tr> <td>A2-08</td> <td>d1-05</td> <td>Base Voltage</td> <td>A2-24</td> <td></td> <td></td> </tr> <tr> <td>A2-09</td> <td>o2-06</td> <td>Operation Direction at Power Up when Using Keypad</td> <td>A2-25</td> <td></td> <td></td> </tr> <tr> <td>A2-10</td> <td>b1-10</td> <td>Run Command at Power up</td> <td>A2-26</td> <td></td> <td></td> </tr> <tr> <td>A2-11</td> <td>E2-00</td> <td>Relay 1 Function Selection</td> <td>A2-27</td> <td></td> <td></td> </tr> <tr> <td>A2-12</td> <td>E2-01</td> <td>Relay 2 Function Selection</td> <td>A2-28</td> <td></td> <td></td> </tr> <tr> <td>A2-13</td> <td>E3-00</td> <td>Terminal A1 Signal Level Selection</td> <td>A2-29</td> <td></td> <td></td> </tr> <tr> <td>A2-14</td> <td>E3-01</td> <td>Terminal A1 Function Selection</td> <td>A2-30</td> <td></td> <td></td> </tr> <tr> <td>A2-15</td> <td>E3-06</td> <td>Terminal A2 Signal Level Selection</td> <td>A2-31</td> <td></td> <td></td> </tr> </tbody> </table>	Parameter	Default	Name	Parameter	Default	Name	A2-00	b1-00	Frequency Command Selection	A2-16	E3-07	Terminal A2 Function Selection	A2-01	b1-01	Run Command Selection	A2-17			A2-02	C1-00	Acceleration Times	A2-18			A2-03	C1-01	Deceleration Times	A2-19			A2-04	C3-00	Torque Compensation Gain	A2-20			A2-05	d1-02	Maximum Output Frequency	A2-21			A2-06	d1-03	Maximum Voltage	A2-22			A2-07	d1-04	Base Frequency	A2-23			A2-08	d1-05	Base Voltage	A2-24			A2-09	o2-06	Operation Direction at Power Up when Using Keypad	A2-25			A2-10	b1-10	Run Command at Power up	A2-26			A2-11	E2-00	Relay 1 Function Selection	A2-27			A2-12	E2-01	Relay 2 Function Selection	A2-28			A2-13	E3-00	Terminal A1 Signal Level Selection	A2-29			A2-14	E3-01	Terminal A1 Function Selection	A2-30			A2-15	E3-06	Terminal A2 Signal Level Selection	A2-31			Range: A1-00 to U4-08
Parameter	Default	Name	Parameter	Default	Name																																																																																																				
A2-00	b1-00	Frequency Command Selection	A2-16	E3-07	Terminal A2 Function Selection																																																																																																				
A2-01	b1-01	Run Command Selection	A2-17																																																																																																						
A2-02	C1-00	Acceleration Times	A2-18																																																																																																						
A2-03	C1-01	Deceleration Times	A2-19																																																																																																						
A2-04	C3-00	Torque Compensation Gain	A2-20																																																																																																						
A2-05	d1-02	Maximum Output Frequency	A2-21																																																																																																						
A2-06	d1-03	Maximum Voltage	A2-22																																																																																																						
A2-07	d1-04	Base Frequency	A2-23																																																																																																						
A2-08	d1-05	Base Voltage	A2-24																																																																																																						
A2-09	o2-06	Operation Direction at Power Up when Using Keypad	A2-25																																																																																																						
A2-10	b1-10	Run Command at Power up	A2-26																																																																																																						
A2-11	E2-00	Relay 1 Function Selection	A2-27																																																																																																						
A2-12	E2-01	Relay 2 Function Selection	A2-28																																																																																																						
A2-13	E3-00	Terminal A1 Signal Level Selection	A2-29																																																																																																						
A2-14	E3-01	Terminal A1 Function Selection	A2-30																																																																																																						
A2-15	E3-06	Terminal A2 Signal Level Selection	A2-31																																																																																																						
A2-32	User-Defined Parameter Automatic Save	Saves the most recently edited parameters. 0: Do not save list of recently edited parameters 1: Save list of recently edited parameters	Default: 1 Range: 0, 1																																																																																																						

Parameter	Name	Description	Setting Range
Group b, Application			
b1: Operation Mode Selection			
b1-00 <8>	Frequency Command Selection 1	0: Keypad 1: Control Circuit Terminal (Analog Input) 2: Terminal Up/Down 3: Modbus Communication 4: Pulse Train Input (Including PWM signal input) 5: Automatic operation	Default: 1 Min.: 0 Max.: 5
b1-01	Run Command Selection 1	0: Keypad 1: Control Circuit Terminal (Sequence Control Input) 2: Modbus Communication	Default: 1 Range: 0, 1, 2
b1-02	Stopping Method Selection	0: Ramp to Stop 1: Coast to Stop 2: DC Braking to Stop 3: Coast to Stop with Timer	Default: 0 Min.: 0 Max.: 3
b1-03	Reverse Rotation Selection	0: Reverse Rotation Enabled Drive accepts a run command of both forward and reverse directions 1: Reverse Rotation disabled Drive can accept only run command of forward direction	Default: 0 Range: 0, 1
b1-05	Run Command Action after Switch	0: Ignore Active Run Command at the New Source If a Run command at the new source is active, the drive will not start or the drive will stop operation if it was running when switching from the old source to the new source. The drive can start only when the Run command is removed and given again. 1: Accept Active Run Command at the New Source If a run command at the new source is active, the drive will accept it and run the motor immediately right after switching from the old source to the new source.	Default: 0 Range: 0, 1
b1-06	Run Command Selection during	0: Run command disabled during Programming 1: Run command enabled during Programming	Default: 0 Range: 0, 1, 2

Parameter	Name	Description	Setting Range
	Programming	2: Prohibit programming during run The programming mode cannot be displayed during run except for monitoring parameter Group U.	
b1-07 <8>	Frequency Command Selection 2	Enabled while E1-00 to E1-07 is set to 4 and the DIP switch is set to OFF 0: Keypad 1: Control Circuit Terminal (Analog Input) 2: Terminal Up/Down 3: Modbus Communication 4: Pulse Train Input (Including PWM signal input) 5: Automatic operation	Default: 0 Min.: 0 Max.: 5
b1-08	Run Command Selection 2	Enabled while E1-00 to E1-07 is set to 4 and the DIP switch is set to OFF 0: Keypad 1: Control Circuit Terminal (Sequence Control Input) 2: Modbus Communication	Default: 0 Range: 0, 1, 2
b1-09	Frequency superposition Selection	0: Disabled 1: Enabled	Default: 0 Range: 0, 1
b1-10	Run Command at Power up	Determines to accept or ignore an active Run command from Remote during power up. 0: Ignore Drive ignores an active run command during power up 1: Accept Drive accepts an active run command at power up and runs the motor immediately.	Default: 0 Range: 0, 1
b1-12	Local/ Remote switching Enable during Operating	0 : Disabled 1 : Enabled	Default : 0 Range: 0, 1
b2: DC Braking			
b2-00	Zero Speed Holding (DC Braking) Start Level	Sets the start frequency for Zero Speed Holding (DC braking). Enabled when b1-02 (Stopping Method Selection) is set to 0 (Ramp to Stop)	Default: 0.5Hz Min.: 0.0 Hz Max.: 10.0 Hz
b2-01	DC Braking Current	Sets the DC braking current as a percentage of the drive rated current	Default: 50% Min.: 0% Max.: 100%

Parameter	Name	Description	Setting Range
b2-02	DC Braking Time at Start	Sets the DC braking time at start to stop a coasting motor before restarting it or to apply braking torque at start when high starting torque is needed. Disabled when set to 0.00.	Default: 0.00 s Min.: 0.00 s Max.: 99.99 s
b2-03	DC Braking Time at Stop	Sets the DC braking time at stop to stop a motor rotating with high inertia. Disabled when set to 0.00.	Default: 0.50s Min.: 0.00s Max.: 99.99s
b3: Speed Search			
b3-00	Speed Search Setting	0 :Disabled 1 :Enabled and searched from the highest frequency 2 : Enabled and searched from the frequency command 3 :Retain 4 :Retain	Default: 0 Range: 0, 1, 2
b3-01	Speed Search Operating Current	Sets the current level as a percentage of the drive rated current below which Speed Search is deactivated.	Default: 120% Min.: 0 % Max.: 140%
b3-02 <9>	Voltage Rocevery Time	Sets the search speed in the output voltage restoring to the time set v / f voltage curve required	Default: 0.6s Min.: 0.3s Max.: 5.0s
b3-03	Retain		
b3-04 <9>	Speed search deceleration time	Sets the search speed in the deceleration time (The maximum output frequency to the minimum output frequency deceleration time)	Default: 2.0s Min.: 0.1s Max.: 10.0s
b3-05 <9>	Search speed in V / f	In order to reduce the speed of search output current by the V / f curve calculated by multiplying the voltage set value b3-05 by adjusting the setting, the speed can be suppressed search output current.	Default: 100% Min.: 10 % Max.: 100%
b4: Timer Function			
b4-00	Timer Function On-Delay Time	Sets the on-delay and off-delay time to switch on/off the timer output.	Default: 0.1 s Min.: 0.1 s Max.: 3000.0 s
b4-01	Timer Function Off-Delay Time		Default: 0.0 s Min.: 0.0 s Max.: 3000.0 s
b5: PID Control			

Parameter	Name	Description	Setting Range
b5-00 <8>	PID Control Setting	0 : PID Control Disabled 1 : PID Control Enabled (D Control for Deviation Signal U4-01) 2 : PID Control Enabled (D Control for Feedback Signal U4-05) 3 : PID Control Enabled (Frequency Command + PID Output from D Controlled Deviation) 4 : PID Control Enabled (Frequency Command + PID Output from D Controlled Feedback) 5 : PID Control Disabled · but b5-14/b5-15 (PID Sleep) and b5-29/b5-30(PID Wake-up) Enabled	Default: 0 Min.: 0 Max.: 5
b5-01 <4>	Proportional Gain Setting (P)	Sets the P gain for PID input.	Default: 1.00 Min.: 0.00 Max.: 25.00
b5-02 <4>	Integral Time Setting (I)	Deviation appears between PID target value and feedback value when using only proportional control. To reduce the deviation, set integral time (I).	Default: 1.0 s Min.: 0.0 s Max.: 360.0 s
b5-03 <4>	Integral Time (I) Limit Setting	Sets the maximum output from the I (integral) control as a percentage of the maximum frequency (d1-02)	Default: 100.0% Min.: 0.0% Max.: 100.0%
b5-04 <4>	Derivative Time (D)	Sets derivative time for D control.	Default: 0.00 s Min.: 0.00 s Max.: 10.00 s
b5-05 <4>	PID Output Limit	Sets the maximum output from PID control as a percentage of the maximum frequency.	Default: 100.0% Min.: 0.0% Max.: 100.0%
b5-06 <4>	PID Bias Voltage Adjustment	Sets the PID bias voltage adjustment as a percentage of the maximum frequency to add to the PID control output.	Default: 0.0% Min.: -100.0% Max.: 100.0%
b5-07 <4>	PID Primary Delay Time	Sets the delay time for the PID output filter.	Default: 0.00 s Min.: 0.00 s Max.: 10.00 s
b5-08	PID Output Selection	0 : Normal PID Output 1 : Reverse PID Output Reverses the +/- sign of the PID output	Default: 0 Range: 0, 1
b5-09	PID Output Gain	Sets a PID output gain	Default: 1.00 Min.: 0.00 Max.: 25.00
b5-10	PID Output Reverse	Determines whether or not a negative PID	Default: 0

Parameter	Name	Description	Setting Range
	Selection	output reverses the drive rotating direction. 0 : Reverse Disabled 1 : Reverse Enabled	Range: 0, 1
b5-11	PID Feedback Low /High Detection Selection	0 : Multi-Function Output Only 1 : Feedback Low /High Alarm The drive continues operation when an alarm is displayed) 2 : Feedback Low /High Fault A fault will cause the drive to stop the motor. 3 : Multi-Function Output only when PID is Disabled Same action as b5-11=0. 4 : Feedback Low /High Alarm (detection disabled when PID is disabled) 5 : Feedback Low /High Fault (detection disabled when PID is disabled) 6 : Multi-Function Output (Keep running without an alarm displayed) 7 : Multi-Function Output Only (detection working when drive running or not)	Default: 0 Min.: 0 Max.: 7
b5-12	PID Feedback Low Detection Level	Sets the PID feedback level used for detection. When the PID feedback falls below this level for longer than the time set to b5-13, PID feedback loss will be detected.	Default: 0% Min.: 0% Max.: 100%
b5-13	PID Feedback Low Detection Time	Sets the PID feedback time used for detection. When the PID feedback falls below the level set to b5-12 for longer than this time, PID feedback loss will be detected.	Default: 1.0 s Min.: 0.0 s Max.: 25.5 s
b5-14	PID Sleep Start Level	Sets the PID level to trigger the drive to sleep.	Default: 0.0Hz Min.: 0.0 Hz Max.: <5>
b5-15	PID Sleep Delay Time	Sets the delay time used to activate/deactivate the PID Sleep function. When this parameter is set to 0.0, PID Sleep function will be stopped.	Default: 0.0 s Min.: 0.0 s Max.: 25.5 s
b5-16	PID Command Acc./Dec. Time	Sets the PID command acceleration /deceleration time used for PID target soft-start function.	Default: 0.0 s Min.: 0.0 s Max.: 20.0 s
b5-17	PID Target Selection	0 :PID Target Disabled 1 :PID Target Enabled	Default: 0 Range: 0, 1
b5-18	PID Target Value	Sets the PID target value as a percentage of the maximum output frequency when b5-17=1 and	Default: 0.00% Min.: 0.00%

Parameter	Name	Description	Setting Range
		no other analog input sets the PID Target.	Max.: 100.00%
b5-19	PID Target Value Units	0 : 0.01Hz 1 : 0.01% (Maximum Frequency is 100%) 2 : r/min. (Number of Motor Poles must be set) 3 : User Defined (Defined by b5-24 and b5-25)	Default: 1 Range: 0, 1, 2, 3
b5-20	PID Output Lower Limit	Sets the lower limit as a percentage of the maximum output frequency set in d1-02 for PID output.	Default: 0.0% Min.: -100.0% Max.: 100.0%
b5-21	PID Input Limit	The higher PID Input value is, the higher PID output value will be. Sets this parameter to limit the PID input value.	Default: 1000.0% Min.: 0.0% Max.: 1000.0%
b5-22	PID Feedback High Detection Level	Sets the level for PID feedback high detection as a percentage of the maximum output frequency. PID feedback high will be detected when the feedback exceeds the level set in b5-22 for longer than the time set in b5-23.	Default: 100% Min.: 0% Max.: 100%
b5-23	PID Feedback High Detection Time	Sets the time for PID feedback high detection. PID feedback high will be detected when the feedback exceeds the level set in b5-22 for longer than the time set in b5-23.	Default: 1.0 s Min.: 0.0 s Max.: 25.5 s
b5-24	PID Target Display Value	Sets a value to display to U4-00 and U4-03 when the drive runs at the maximum output frequency	Determined by b5-19 Min.: 1 Max.: 60000
b5-25	PID Target Display Digits	Sets the number of decimal places to display. 0 : No Decimal Places 1 : 1 Decimal Place 2 : 2 Decimal Places 3 : 3 Decimal Places	Determined by b5-19 Min.: 0 Max.: 3
b5-26	Frequency Command Display During PID	0 : Displays frequency command after the PID compensation. 1 : Displays frequency command before the PID compensation.	Default: 0 Range: 0, 1
b5-27	PID Output Direction 2	Sets the direction when PID output value is minus. 0 : Reverse is not allowed. 1 : Reverse is allowed.	Default: 1 Range: 0, 1
b5-28	PID Disconnection Output Frequency	When a PID feedback disconnection alarm occurs, the drive will run at the frequency set to b5-28, and return to PID control when disconnection alarm is reset.	Default: 30.0 Hz Min.: 0.0Hz Max.: Determined by d1-02, L2-00, d1-13

Parameter	Name	Description	Setting Range
b5-29 <8>	PID Wake-up Level	Sets the PID Wake-up level	Default:0.0 Hz Min.:0.0 Hz Max.:<5>
b5-30 <8>	PID Wake-up deley time	Sets the PID Wake-up delay time	Default: 0.0 s Min.: 0.0 s Max.: 25.5 s
b6: Dwell Function			
b6-00	Dwell Frequency at Start	Sets the frequency to b6-00 used to be held for the time set in b6-01 during acceleration.	Default: Determined by A1-02 Min.: 0.0 Hz Max.: Determined by d1-02, L2-00, d1-13
b6-01	Dwell Time at Start		Default: 0.0 s Min.: 0.0 s Max.: 10.0 s
b6-02	Dwell Frequency at Stop	Sets the frequency to b6-02 used to be held for the time set in b6-03 during deceleration.	Default: 0.0Hz Min.: 0.0 Hz Max.: Determined by d1-02, L2-00, d1-13
b6-03	Dwell Time at Stop		Default: 0.0 s Min.: 0.0 s Max.: 10.0 s
b9 : Position Control / Zero Speed Holding			
b9-02	Zero Speed Holding On/ Off	0 : Zero Speed Holding Disabled. Drive coasts to stop when the frequency is zero. 1 : Zero Speed Holding Enabled. Zero Speed Holding starts when the frequency is zero. The holding current is set in b2-01 and it will be limited to below 20% of the drive rated current.	Default: 0 Min.: 0 Max.: 1
b9-03	Zero Speed Holding Time	Sets the Zero Speed Holding time. Drive will coast to stop when the Zero Speed Holding time is longer than this setting. Set 00.00 to disable Zero Speed Holding or set 99.99 to enable this function continuesely .	Default: 0.10sec Min.: 00.00sec Max.: 99.99sec
Group C, Tuning			

Parameter	Name	Description	Setting Range
C1: Acc./Dec. Time			
C1-00 <4>	Acceleration Time 1	Sets the time that the drive accelerates from 0Hz to the maximum output.	Default: 10.0 s Min.: 0.0 s Max.: 6000.0 s
C1-01 <4>	Deceleration Time 1	Sets the time that the drive decelerates from the maximum output to 0Hz.	
C1-02 <4>	Acceleration Time 2	Sets the time that the drive accelerates from 0Hz to the maximum output.	
C1-03 <4>	Deceleration Time 2	Sets the time that the drive decelerates from the maximum output to 0Hz.	
C1-04 <4>	Acceleration Time 3 (Acceleration Time 1 for Motor 2)	Sets the time that the drive accelerates from 0Hz to the maximum output.	
C1-05 <4>	Deceleration Time 3 (Deceleration Time 1 for Motor 2)	Sets the time that the drive decelerates from the maximum output to 0Hz.	
C1-06 <4>	Acceleration Time 4 (Acceleration Time 2 for Motor 2)	Sets the time that the drive accelerates from 0Hz to the maximum output.	
C1-07 <4>	Deceleration Time 4 (Deceleration Time 2 for Motor 2)	Sets the time that the drive decelerates from the maximum output to 0Hz.	
C1-08	Fast Stop Time	Sets the time to stop the drive faster.	
C1-09	Acc./Dec. Time Unit Selection	Set the units of time for C1-00 to C1-08. 0 : 0.01 s (0.00 to 600.00 s) 1 : 0.1 s (0.00 to 6000.0 s)	Default: 1 Range: 0, 1
C1-10	Acc./Dec. Time Switch Frequency	Sets the frequency level. The drive will switch the acceleration and deceleration time at this level.	Default: 0.0 Hz Min.: 0.0 Hz Max.: Determined by d1-02, L2-00
C1-11	Jog Acc. Time	Sets the time to accelerate from 0 Hz to Jog Frequency Command (L1-16).	Default: 10.0 s Min.: 0.0 s Max.: 6000.0 s
C1-12	Jog Dec. Time	Sets the time to decelerate from Jog Frequency Command (L1-16) to 0 Hz.	Default: 10.0 s Min.: 0.0 s Max.: 6000.0 s

Parameter	Name	Description	Setting Range
C2: S-Curve Characteristics			
C2-00	S-Curve Characteristic at Acc. Start	Sets S-curve times for each acceleration or deceleration. Actual Acceleration Time= Determined Acc. Time+(C2-00+C2-01)/ 2 Actual Deceleration Time= Determined Dec. Time+(C2-02+C2-03) / 2	Default: 0.20 s Min.: 0.00 s Max.: 10.00 s
C2-01	S-Curve Characteristic at Acc. End		Default: 0.20 s Min.: 0.00 s Max.: 10.00 s
C2-02	S-Curve Characteristic at Dec. Start		Default: 0.20 s Min.: 0.00 s Max.: 10.00 s
C2-03	S-Curve Characteristic at Dec. End		Default: 0.20 s Min.: 0.00 s Max.: 10.00 s
C3: Torque Compensation			
C3-00 <4>	Torque Compensation Gain	Sets the gain for the motor 1 Torque compensation	Default: Determined by A1-02 Min.:0.00 Max.:2.50
C3-02 <4>	Torque Compensation Primary Delay Time	Sets the Torque compensation primary delay time.	Default: Determined by A1-02 Min.: 0 ms Max.:10000 ms
C5: Slip Compensation			
C5-00 <4>	Slip Compensation Gain	Sets the slip compensation gain to improve the speed accuracy for heavy loads.	Default: Determined by A1-02 Min.: 0.0 Max.: 2.5
C5-01 <4>	Slip Compensation Primary Delay Time	Sets the slip compensation primary delay time to stabilize the motor speed or to improve the speed response.	Default: Determined by A1-02 Min.: 0 ms Max.:10000ms
C5-02	Slip Compensation Limit	Sets the maximum slip compensation as percentage of the rated slip for motor 1.	Default: 200% Min.: 0 % Max.: 250 %
C6: Carrier Frequency			

Parameter	Name	Description	Setting Range
C6-00	Carrier Frequency Selection	<p>Sets the switching frequency of the drive output transistors. Adjust this setting to reduce audible noise and leakage current.</p> <p>0: Determined by C6-01 to C6-03</p> <p>1: Retain</p> <p>2: 2.0 kHz</p> <p>3: 3.0 kHz</p> <p>4: 4.0 kHz</p> <p>5: 5.0 kHz</p> <p>6: 6.0 kHz</p> <p>7: 7.0 kHz</p> <p>8: 8.0 kHz</p> <p>9: 9.0 kHz</p> <p>10: 10.0 kHz</p> <p>11: 11.0 kHz</p> <p>12: 12.0 kHz</p> <p>13: 13.0 kHz</p> <p>14: 14.0 kHz</p> <p>15: 15.0 kHz</p>	<p>Default: Determined by A1-02 and o2-03. Once A1-06 is redefined, the default will be changed accordingly</p> <p>Min.: 0</p> <p>Max.: 15</p>
C6-01	Maximum Carrier Frequency	<p>Set 0 to parameter C6-00 to enable this setting.</p> <p>Sets the maximum and minimum carrier frequency in V/F Control that the drive will adjust carrier frequency according to the output frequency.</p>	<p>Default: Determined by C6-00</p> <p>Min.: 2.0 kHz</p> <p>Max.: 15.0 kHz</p>
C6-02	Minimum Carrier Frequency		<p>Default: Determined by C6-00</p> <p>Min.: 2.0 kHz</p> <p>Max.: 15.0 kHz</p>
C6-03	Carrier Frequency Proportional Gain		<p>Default: Determined by C6-00</p> <p>Min.: 0</p> <p>Max.: 99</p>
C7 : SVVC Command			
C7-00	Proportional Gain	<p>This gain adjustment depending on the application field, if the load is heavy increase this value, otherwise reduce this value</p>	<p>Default: 30%</p> <p>Min.: 1%</p> <p>Max.: 100%</p>

Parameter	Name	Description	Setting Range
Group L, Frequency Command			
L1: Frequency Command			
L1-00 <4>	Frequency Command 1	<p>To use speed commands for each multi-step speed, set E1-□□ to 5, 6, 7 and 8 (multi-step speed command 1, 2, 3, 4). Sets E1-□□ to 9 for Jog frequency command.</p> <p>The upper limit is determined by d1-02 and L2-00.</p> <p>In PM Closed-Loop Vector Control, o1-00 will be automatically set to 1 with the unit set to %.</p> <p>When L2-00 (Frequency Upper Limit) is adjusted, the exceeded frequency in L1-00 to L1-15 will be automatically set to the upper limit determined in L2-00.</p>	Default: 5.00Hz Min.: 0.00Hz Max.: Determined by d1-02, L2-00
L1-01 <4>	Frequency Command 2		Default: 8.00 Hz Min.: 0.00 Hz Max.: Determined by d1-02, L2-00
L1-02 <4>	Frequency Command 3		Default: 10.00Hz Min.: 0.00 Hz Max.: Determined by d1-02, L2-00
L1-03 <4>	Frequency Command 4		Default: 12.00Hz Min.: 0.00Hz Max.: Determined by d1-02, L2-00
L1-04 <4>	Frequency Command 5		Default: 15.00Hz Min.: 0.00Hz Max.: Determined by d1-02, L2-00
L1-05 <4>	Frequency Command 6		Default: 20.00Hz Min.: 0.00Hz Max.: Determined by d1-02, L2-00
L1-06 <4>	Frequency Command 7		Default: 25.00Hz Min.: 0.00Hz Max.: Determined by d1-02, L2-00
L1-07 <4>	Frequency Command 8		Default: 30.00Hz Min.: 0.00Hz Max.: Determined by d1-02, L2-00
L1-08 <4>	Frequency Command 9		Default: 35.00Hz Min.: 0.00Hz Max.: Determined by d1-02, L2-00
L1-09	Frequency	Default: 40.00Hz	

Parameter	Name	Description	Setting Range
<4>	Command 10	<p>To use speed commands for each multi-step speed, set E1-□□ to 5, 6, 7 and 8 (multi-step speed command 1, 2, 3, 4). Sets E1-□□ to 9 for Jog frequency command.</p> <p>The upper limit is determined by d1-02 and L2-00.</p> <p>In PM Closed-Loop Vector Control, o1-00 will be automatically set to 1 with the unit set to %.</p> <p>When L2-00 (Frequency Upper Limit) is adjusted, the exceeded frequency in L1-00 to L1-15 will be automatically set to the upper limit determined in L2-00.</p>	Min.: 0.00Hz Max.: Determined by d1-02, L2-00
L1-10 <4>	Frequency Command 11		Default: 42.00Hz Min.: 0.00Hz Max.: Determined by d1-02, L2-00
L1-11 <4>	Frequency Command 12		Default: 45.00Hz Min.: 0.00Hz Max.: Determined by d1-02, L2-00
L1-12 <4>	Frequency Command 13		Default: 50.00Hz Min.: 0.00Hz Max.: Determined by d1-02, L2-00
L1-13 <4>	Frequency Command 14		Default: 50.00Hz Min.: 0.00Hz Max.: Determined by d1-02, L2-00
L1-14 <4>	Frequency Command 15		Default: 50.00Hz Min.: 0.00Hz Max.: Determined by d1-02, L2-00
L1-15 <4>	Frequency Command 16		Default: 50.00Hz Min.: 0.00Hz Max.: Determined by d1-02, L2-00
L1-16 <4>	Jog Frequency Command		Sets the Jog frequency command.
L2: Frequency Upper/ Lower Limit			
L2-00	Frequency Command Upper Limit	Sets the upper limit	Default: d1-02 Min.: 0.0 Hz Max.: d1-02*110%
L2-01	Frequency Command Lower Limit	Sets the lower limit as a percentage of the maximum output frequency	Default: 0.0Hz Min.: 0.0 Max.: d1-02*110%
L3: Jump Frequency			
L3-00	Jump Frequency 1	Sets the Jump frequency range to avoid	Default: 0.0 Hz

Parameter	Name	Description	Setting Range
L3-01	Jump Frequency 2	operation at the speed causing resonance in the machinery. Set L3-00 to L3-03 to 0.0 Hz to disable Jump frequency. When setting more than 1 Jump frequency, follow the condition below. $L3-00 \leq L3-01 \leq L3-02$	Min.: 0.0 Hz Max.: 20.0 Hz
L3-02	Jump Frequency 3		
L3-03	Jump Frequency Range	Sets the Jump frequency range to avoid.	Default: 1.0 Hz Min.: 0.0 Hz Max.: 20.0 Hz
L4: Frequency Command Hold and Up/Down 2 Command			
L4-00	Up/ Down Frequency Command Hold	Determines whether or not to save the frequency command or the frequency bias (Up/Down 2) value when the Stop command is entered or the power supply is shut off. 0 : Clear the Up/Down frequency at stop 1 : Save the Up/Down frequency at stop 2 : Accept the Up/Down frequency at stop	Default: 0 Range: 0, 1, 2
L4-01 <4>	Frequency Command Bias (Up/Down 2)	Sets the bias used to add to or subtract from the frequency command by Up/Down 2.	Default: 0.00 Hz Min.: 0.00 Hz Max.: 99.99 Hz
L4-02 <4>	Frequency Command Acc./Dec Setting (Up/Down 2)	Sets the acceleration/deceleration times to increase or decrease the frequency command bias for Up/Down 2. 0 : Current Acc./Dec. Time 1 : Acc./Dec. Time 4 set in C1-06 and C1-07	Default: 0 Range: 0, 1
L4-03 <4>	Up/Down Frequency Command Save	Saves the frequency command from Up/Down 1 or Up/Down 2	Default: 0.00Hz Min.: 0.00 Hz Max.: Determined by d1-02, d1-13 and L2-00
L4-04	Frequency Command Hold	0: Disabled 1: Enabled	Default: 0 Range 0, 1
L6: Offset Frequency			
L6-00 <4>	Offset Frequency 1	Sets the offset value as a percentage of the maximum output frequency to add to or subtract from the frequency command. Select the offset frequency in E1-□□= 53, 54 and 55 (Offset Frequency 1 to 3).	Default: 0.0% Min.: -100.0% Max.: 100.0%
L6-01	Offset Frequency 2	Sets the offset value as a percentage of the	Default: 0.0%

Parameter	Name	Description	Setting Range
<4>		maximum output frequency to add to or subtract from the frequency command. Select the offset frequency in E1-□□= 53, 54 and 55 (Offset Frequency 1 to 3).	Min.: -100.0% Max.: 100.0%
L6-02 <4>	Offset Frequency 3	Sets the offset value as a percentage of the maximum output frequency to add to or subtract from the frequency command. Select the offset frequency in E1-□□= 53, 54 and 55 (Offset Frequency 1 to 3).	Default: 0.0% Min.: -100.0% Max.: 100.0%
L7 : Automatic operation			
L7-00 <8>	Automatic operation mode selection	0 : Disabled 1 : One cycle mode, when the mode is end, the motor is stop, and then reset to restart 2 : One cycle mode, when the mode is end, the motor is stop, and then restart from final program 3 : One cycle mode, the mode is operating to end according to last frequency of program, and then reset to restart 4 : One cycle mode, the mode is running to end according to last frequency of program, and then restart from final program 5 : Continuous cycle mode, reset to restart 6 : Continuous cycle mode, restart from final program	Default : 0 Min. : 0 Max. : 6
L7-01 <8>	1 st operating time	Automatic operation of each segment time	Default : 0.0 Min. : 0.0 Max. : 6000.0
L7-02 <8>	2 nd operating time		Default : 0.0 Min. : 0.0 Max. : 6000.0
L7-03 <8>	3 rd operating time		Default : 0.0 Min. : 0.0 Max. : 6000.0
L7-04 <8>	4 th operating time		Default : 0.0 Min. : 0.0 Max. : 6000.0
L7-05 <8>	5 th operating time		Default : 0.0 Min. : 0.0

Parameter	Name	Description	Setting Range
			Max. : 6000.0
L7-06 <8>	6 th operating time		出 Default : 0.0 Min. : 0.0 Max. : 6000.0
L7-07 <8>	7 th operating time		Default : 0.0 Min. : 0.0 Max. : 6000.0
L7-08 <8>	8 th operating time		Default : 0.0 Min. : 0.0 Max. : 6000.0
L7-09 <8>	9 th operating time		Default : 0.0 Min. : 0.0 Max. : 6000.0
L7-10 <8>	10 th operating time		Default : 0.0 Min. : 0.0 Max. : 6000.0
L7-11 <8>	11 th operating time		Default : 0.0 Min. : 0.0 Max. : 6000.0
L7-12 <8>	12 th operating time		Default : 0.0 Min. : 0.0 Max. : 6000.0
L7-13 <8>	13 th operating time		Default : 0.0 Min. : 0.0 Max. : 6000.0
L7-14 <8>	14 th operating time		Default : 0.0 Min. : 0.0 Max. : 6000.0
L7-15 <8>	15 th operating time		Default : 0.0 Min. : 0.0 Max. : 6000.0
L7-16 <8>	16 th operating time		Default : 0.0 Min. : 0.0 Max. : 6000.0
L7-17 <8>	1 st operating direction	Automatic operation of each segment direction 0 : Stop 1 : Forward	Default : 0 Min. : 0 Max. : 2
L7-18	2 nd operating	2 : Reverse	Default : 0

Parameter	Name	Description	Setting Range
<8>	direction		Min. : 0 Max. : 2
L7-19 <8>	3 rd operating direction		Default : 0 Min. : 0 Max. : 2
L7-20 <8>	4 th operating direction		Default : 0 Min. : 0 Max. : 2
L7-21 <8>	5 th operating direction		Default : 0 Min. : 0 Max. : 2
L7-22 <8>	6 th operating direction		Default : 0 Min. : 0 Max. : 2
L7-23 <8>	7 th operating direction		Default : 0 Min. : 0 Max. : 2
L7-24 <8>	8 th operating direction		Default : 0 Min. : 0 Max. : 2
L7-25 <8>	9 th operating direction		Default : 0 Min. : 0 Max. : 2
L7-26 <8>	10 th operating direction		Default : 0 Min. : 0 Max. : 2
L7-27 <8>	11 th operating direction		Default : 0 Min. : 0 Max. : 2
L7-28 <8>	12 th operating direction		Default : 0 Min. : 0 Max. : 2
L7-29 <8>	13 th operating direction		Default : 0 Min. : 0 Max. : 2
L7-30 <8>	14 th operating direction		Default : 0 Min. : 0 Max. : 2

Parameter	Name	Description	Setting Range
L7-31 <8>	15 th operating direction		Default : 0 Min. : 0 Max. : 2
L7-32 <8>	16 th operating direction		Default : 0 Min. : 0 Max. : 2
L7-33 <8>	The unit of operating time selection	0 : sec 1 : hr	Default : 0 Min. : 0 Max. : 1
Group d, Motor Parameters			
d1: V/F Characteristics			
d1-00	Input Voltage Setting	Sets the input voltage of the drive. Always set the input voltage of the drive (not motor) to this parameter.	Default: 230 V Min.: 155 V Max.: 255V <3>
d1-01	V/F Pattern Selection	0 : 50 Hz (Constant Torque Characteristic 1) 1 : 60 Hz (Constant Torque Characteristic 2) 2 : 60 Hz (Constant Torque Characteristic 3), 50 Hz base 3 : 72 Hz (Constant Torque Characteristic 4), 60 Hz base 4 : 50 Hz (Derated Torque Characteristic 1) 5 : 50 Hz (Derated Torque Characteristic 2) 6 : 60 Hz (Derated Torque Characteristic 3) 7 : 60 Hz (Derated Torque Characteristic 4) 8 : 50 Hz (High Starting Torque Characteristic 1) 9 : 50 Hz (High Starting Torque Characteristic 2) A : 60 Hz(High Starting Torque Characteristic 3) B : 60 Hz(High Starting Torque Characteristic 4) C : 90 Hz, 60 Hz base D : 120 Hz, 60 Hz base E : 180 Hz, 60 Hz base F : 60Hz (Constant Torque Characteristic) (Default)	Default: F Range: 0 to 9; A to F
d1-02	Maximum Output Frequency	When d1-01 ≤ E, parameters d1-02 to d1-11 can be used to monitor the V/F pattern.	Default: <1> Min.: 25.0 Hz Max.: 400.0 Hz
d1-03	Maximum Voltage	When d1-01 = F, parameters d1-02 to d1-11 can	Default: <1>

Parameter	Name	Description	Setting Range	
		be used to create a V/F pattern.	Min.: 0.0 V Max.: 255.0 V <3>	
d1-04	Base Frequency		Default: <1> Min.: 0.0 Hz Max.: Defined by d1-02	
d1-05	Base Voltage		Default: <1> Min.: 0.0 V Max.: 255.0 V <3>	
d1-06	Middle Output Frequency		Default: <1> Min.: 0.0 Hz Max.: Defined by d1-02	
d1-07	Middle Output Frequency Voltage		Default: <1> Min.: 0.0 V Max.: 255.0 V <3>	
d1-08	Minimum Output Frequency		Default: <1> Min.: 0.0 Hz Max.: Defined by d1-02	
d1-09	Minimum Output Frequency Voltage		Default: <1> Min.: 0.0 V Max.: 255.0 V <3>	
d1-10	Middle Output Frequency 2		Default: 0.0 Hz Min.: 0.0 Hz Max.: Defined by d1-02	
d1-11	Middle Output Frequency Voltage 2		Default: 0.0 V Min.: 0.0 V Max.: 255.0 V <3>	
d1-23	Mode setting for V/F separation		0 : V/F 1 : V/F complete separation 2 : V/F half separation	Default: 0 Min.: 0 Max.: 2
d1-24	Voltage source for V/F separation		0 : Setting by d1-25 1 : Analog setting corresponds to the E3-01 or E3-07 = 20	Default: 0 Min.: 0 Max.: 1
d1-25	Voltage digital setting for V/F separation	Setting voltage digital for V/F separation	Default: A1-03 Min.: 0V Max.: Defined to the rated motor voltage	

Parameter	Name	Description	Setting Range
d1-26	Voltage rise time of V/F separation	Setting voltage rise time for V/F separation	Default:10.0 s Min.: 0.1 s Max.: 1000.0 s
d1-27	Voltage decline time of V/F separation	Setting voltage decline time for V/F separation	Default: 10.0 s Min.: 0.1 s Max.: 1000.0 s
d1-28	Stop mode selection upon V/F separation	0 : Frequency and voltage declining to 0 independently 1 : Frequency declining to 0 after voltage declines to 0	Default: 0 Min.: 0 Max.: 1
d2: Motor Parameters			
d2-00	Motor Rated Current	Sets the motor rated current. This will be set automatically during Auto-Tuning.	Default: o2-03, A1-06 Min.: 10% of drive rated current Max.: 200% of drive rated current
d2-01	Motor Rated Speed (For Slip Compensation)	Sets the motor rated speed used for slip compensation. This will be set automatically during Auto-Tuning. Alarm OPE17 will be detected when this value is set incorrectly.	Default: o2-03, A1-06 Min.: 0 rpm Max.: 60000 rpm
d2-02	Motor No-Load Current	Sets the motor no-load current. This will be set automatically during Auto-Tuning.	Default: o2-03, A1-06 Min.: 0.0 A Max.: d2-00 (excluding d2-00)
d2-03	Number of Motor Poles	Sets the number of motor poles. This will be set automatically during Auto-Tuning.	Default: 4 Min.: 2 Max.: 48
d2-04	Motor Line-to-Line Resistance	Sets the line-to-line resistance. This will be set automatically during Auto-Tuning.	Default: o2-03, A1-06 Min.: 0.000 Ω Max.:65.000 Ω
d2-05	Motor Leakage Inductance	Sets the voltage drop caused by the motor leakage inductance relative to the motor rated frequency and current. This will be set automatically during Auto-Tuning.	Default: o2-03, A1-06 Min.: 0.00 mH Max.:650.00 mH
d2-06	Motor Rotor Resistance	Sets the motor rotor resistance. This will be set automatically during Auto-Tuning.	Default: o2-03, A1-06 Min.: 0.000 Ω Max.:65.000 Ω
d2-07	Motor Mutual Inductance	Sets the motor mutual inductance. This will be set automatically during Auto-Tuning.	Default: o2-03, A1-06 Min.: 0.0 mH Max.:6500.0 mH

Parameter	Name	Description	Setting Range
d2-10	Motor Rated Capacity	Sets the motor rated capacity. This will be set automatically during Auto-Tuning. (1HP = 0.746 kW)	Default: 02-03 Min.: 0.00 kW Max.: 650.00kW
Group E, Multi-Function Terminals			
E1: Multi-Function Digital Inputs			
E1-00	Terminal S1 Function Selection	0 : 2-Wire Sequence Control (Forward/Stop) / 3-Wire Sequence Control (Stop)	Default : 0 Range: 0 to 75 / 100 to 175
E1-01	Terminal S2 Function Selection	1 : 2-Wire Sequence Control (Reverse/Stop) / 3-Wire Sequence Control (Stop)	Default : 1 Range: 0 to 75 / 100 to 175
E1-02	Terminal S3 Function Selection	2 : 3-Wire Sequence 3 : Local/Remote Selection	Default : 23 Range: 0 to 75 / 100 to 175
E1-03	Terminal S4 Function Selection	4 : Command Source 1/2 Selection 5 to 8: Multi-Step Speed Command 1 to 4 9 : Jog Frequency	Default : 39 Range: 0 to 75 / 100 to 175
E1-04	Terminal S5 Function Selection	10 : Up Command 11: Down Command 12: Up 2 Command	Default : 5 Range: 0 to 75 / 100 to 175
E1-05	Terminal S6 Function Selection	13: Down 2 Command 14, 15: FJOG/RJOG Command 16: Acc./Dec. Time Selection 1 17: Acc./Dec. Time Selection 2	Default : 6 Range: 0 to 75 / 100 to 175
E1-06	Terminal S7 Function Selection	18: Acc./Dec. Ramp Hold 19: Base Block 21: Fast Stop (Normal Open) 23 to 38 : External Fault 39: Fault Reset 40 : oH2 (AC drive Overheat Alarm) 41 : Multi-Function Analog Input Selection 45: Communication Mode 46: PID Disable 47: PID Integral Reset 48: PID Integral Hold 49: PID Soft-Start On/Off 50: PID Input Characteristics Switch 51: Motor 1/2 Switch 52: Timer Input 53, 54, 55: Offset Frequency 1/ 2/ 3 57: KEB Command 1 (Normal Open) 60: Program Lockout	Default : 9 Range: 0 to 75 / 100 to 175

Parameter	Name	Description	Setting Range
		61: Analog Frequency Command Hold 63: External Speed Search Command 65: DC Braking 69: Drive Enabled 74: S7 is set to pulse input or PWM 75: Reset automatic operation program	
E1-08	Terminal command mode	0: Two-line / Three-line mode 1 1: Two-line / Three-line mode 2	Default: 0 Min.: 0 Max.: 1
E2: Multi-Function Digital Output			
E2-00	Relay 1 Function Selection	0 : During Run 1 : Zero Speed Holding 2 : Frequency (Speed) Agree	Default: 11 Range: 0 to 52 / 100 to 152
E2-01	Relay 2 Function Selection	3 : User-Defined Frequency (Speed) Agree 4 : Drive Ready 5 : Uv (Undervoltage) Detection	Default: 0 Range: 0 to 52 / 100 to 152
E2-02	D1-DC Function Selection (Open Collector)	6 : During Baseblock 7 : Retain 8 : Frequency Command Source 9 : Frequency Command Loss 10: Run Command Source 11 : Fault 12 : Communication Mode 13 : Alarm 14 : Fault Restart 15 : Timer Output 16 : Frequency (FOUT) Detection 1 17 : Frequency (FOUT) Detection 2 18: Overvoltage/ Undervoltage Detection 1 (normal open) 20: Overvoltage/ Undervoltage Detection 2 (normal open) 22 : During Reverse 23: Motor 1/ 2 Selection 24: During Regeneration 25 : During Restart 26 : Motor Overload Pre-Alarm (oL1) 27 : Drive Overheat Pre-Alarm (oH) 28 : Retain	Default: 1 Range: 0 to 52 / 100 to 152

Parameter	Name	Description	Setting Range
		29 : Mechanical Weakening Detection (Normal Open) 31 : During Torque Limit (Current Control) 32 : During Speed Limit 33 : During Speed Limit Circuit Operation (For Torque Control) 34 : Zero Speed Holding Stop 35 : During Frequency Output 36 : Drive Enabled 37 : Watt Hour Pulse Output 38 : Local/Remote Mode 39 : During Speed Search 40 : PID Feedback Low 41 : PID Feedback High 42 : During KEB Operation 43 : Retain 44 : During Fast Stop 45 : Internal Cooling Fan Alarm 49 : Brake control (Desired frequency attained) 50 : Set D1 as pulse output 51 : Automatic operation cycle is completed <8> 52 : Automatic operation phase is completed <8> 100 to 152: 0 to 52 with Inverse Output	
E2-05	Watt Hour Output Unit	Selects the output unit for the terminal assigned to E2-00 or E2-03=37 for one pulse signal. 0: 0.1 kWh units 1: 1 kWh units 2: 10 kWh units 3: 100 kWh units 4: 1000 kWh units	Default: 0 Min.: 0 Max.: 4
E2-06	Relay 1 On Delay	The definition of a relay1 on delay time.	Default: 0.0s Min.: 0.0s Max.: 3600.0s
E2-07	Relay 1 Off Delay	The definition of a relay1 off delay time.	Default: 0.0s Min.: 0.0s Max.: 3600.0s
E2-08	Relay 2 On Delay	The definition of a relay2 on delay time.	Default: 0.0s Min.: 0.0s Max.: 3600.0s
E2-09	Relay 2 Off Delay	The definition of a relay2 off delay time.	Default: 0.0s Min.: 0.0s

Parameter	Name	Description	Setting Range
			Max.: 3600.0s
E3: Multi-Function Analog Input			
E3-00	Terminal A1 Signal Level Selection	0 : 0 to 10 V 1 : -10 to 10 V	Default: 0 Range: 0, 1
E3-01	Terminal A1 Function Selection	0 : Main Frequency Command 1 : Frequency Gain 2 : Output Frequency Lower Limit 3 : Auxiliary Frequency Command 4 : Output Voltage Bias 5 : Acc./Dec. Time Gain (Decrease Only) 6 : DC Braking (DB) Current 7 : Stall Prevention Level During Run 8 : PID Feedback 9 : PID Target 10: Differential PID Feedback 11 : Overtorque/ Undertorque Detection 18: Communication Mode 1 19 : Communication Mode 2 20 : V/F separation voltage	Default: 0 Range: 0 to 20
E3-02 <4>	Terminal A1 Input Gain	Sets the terminal A1 input gain as a percentage when inputting 10V	Default: 100.0 % Min.: -999.9 % Max.: 999.9 %
E3-03 <4>	Terminal A1 Input Voltage Bias	Sets the terminal A1 input voltage bias as a percentage when inputting 0V	Default: 0.0 % Min.: -999.9 % Max.: 999.9 %
E3-05	Terminal A1 Input Filter Time	Sets the terminal A1 primary delay filter time, which can eliminate the interference	Default: 0.05 s Min.: 0.00 s Max.: 2.00 s
E3-06	Terminal A2 Signal Level Selection	0 : 0 to 20 mA 1 : 4 to 20 mA 2 : 0 to 10 V 3 : 0 to 5 V	Default: 1 Range: 0, 1, 2, 3

Parameter	Name	Description	Setting Range
E3-07	Terminal A2 Function Selection	0 : Main Frequency Command 1 : Frequency Gain 2 : Output Frequency Lower Limit 3 : Auxiliary Frequency Command 4 : Output Voltage Bias 5 : Acc./Dec. Time Gain (Decrease Only) 6 : DC Braking (DB) Current 7 : Stall Prevention Level During Run 8 : PID Feedback 9 : PID Target Value 10: Differential PID Feedback 11 : Overtorque/ Undertorque Detection 18: Communication Mode 1 19 : Communication Mode 2 20 : V/F separation voltage	Default: 8 Range: 0 to 20
E3-08 <4>	Terminal A2 Input Gain	Sets the terminal A2 input gain as a percentage when inputting 10V	Default: 100.0 % Min.: -999.9 % Max.: 999.9 %
E3-09 <4>	Terminal A2 Input Voltage Bias	Sets the terminal A2 input voltage bias as a percentage when inputting 0V.	Default: 0.0% Min.: -999.9 % Max.: 999.9 %
E3-10	Terminal A2 (4-20mA) Loss Action Selection	0 : Disabled 1 : Run According to P4-03 Setting and Display ANL 2 : Disacceleration to 0Hz and Display ANL 3 : Drive Stop and Display ACE	Default: 0 Range: 0 to 3
E3-11	Terminal A2 Input Filter Time	Sets the terminal A2 primary delay filter time, which can eliminate the interference.	Default: 0.05 s Min.: 0.00 s Max.: 2.00 s
E3-12	Analog Input Terminal Enable/ Disable Selection	Enables the analog inputs when Multi-Function Terminal Input E1-□□ = 41 (Multi-Function Analog Input Selection). 0: Both Terminal A1 and A2 Disabled 1: Only Analog Input Terminal A1 Enabled 2: Only Analog Input Terminal A2 Enabled 3: Both Terminal A1 and A2 Enabled	Default: 3 Range: 0, 1, 2, 3
E4: Multi-Function Analog Output			

Parameter	Name	Description	Setting Range
E4-00	Terminal FM Signal Level Selection	0 : 0 to 10 V 1 : -10 to 10 V	Default: 0 Range: 0, 1
E4-01	Terminal FM Monitor Selection	Selects the terminal FM monitor. 0 : Frequency Command 1 : Output Frequency 2 : Output Current 3 : Motor Speed 4 : Output Voltage 5 : DC Voltage 6 : Output Power 7 : Torque Command 8 : AI1 Input 9 : AI2 Input 10 : Soft Starter Output Frequency 11 : Pulse Train Input	Default: 1 Range: 0 to 11
E4-02 <4>	Terminal FM Monitor Gain	Sets the terminal FM monitor gain.	Default: 100.0 % Min.: -999.9 % Max.: 999.9 %
E4-03 <4>	Terminal FM Monitor Voltage Bias	Sets the terminal FM voltage bias.	Default: 0.0 % Min.: -999.9 % Max.: 999.9 %
E4-04	Terminal AM Signal Level Selection	0: 0 to 10 V 1: 0 to 20 mA 2: 4 to 20 mA	Default: 0 Range: 0, 1, 2
E4-05	Terminal AM Monitor Selection	Selects the terminal AM monitor. 0 : Frequency Command 1 : Output Frequency 2 : Output Current 3 : Motor Speed 4 : Output Voltage 5 : DC Voltage 6 : Output Power 7 : Torque Command 8 : AI1Input 9 : AI2Input 10: Soft Starter Output Frequency 11 : Pulse Train Input	Default: 2 Range: 0 to 11
E4-06 <4>	Terminal AM Monitor Gain	Sets the terminal AM gain.	Default: 100.0 % Min.: -999.9 % Max.: 999.9 %
E4-07	Terminal AM	Sets the terminal AM voltage bias.	Default: 0.0 %

Parameter	Name	Description	Setting Range
<4>	Monitor Voltage Bias		Min.: -999.9 % Max.: 999.9 %
E5:Pulse Train Input/ Output			
E5-00 <7>	Pulse Train Input Function Selection	Selects the function for terminal RP. 0 : Frequency Command 1 : PID Feedback 2 : PID Target	Default: 0 Range: 0, 1, 2
E5-01 <4> <7>	Pulse Train Input Scaling	Sets the frequency equal to 100% frequency in Hz.	Default: 1440 Hz Min.: 100 Hz Max.: 32000 Hz
E5-02 <4> <7>	Pulse Train Input Gain	Sets the level of the input gain to terminal RP.	Default: 100.0% Min.: 0.0 % Max.: 1000.0 %
E5-03 <4> <7>	Pulse Train Input Voltage Bias	Sets the level of the input voltage bias when no signal (0Hz) is input to terminal RP.	Default: 0.0% Min.: -100.0 Max.: 100.0
E5-04 <4> <7>	Pulse Train Input Filter Time	Sets the pulse train input primary filter time in seconds.	Default: 0.10 s Min.: 0.00 s Max.: 2.00 s
E5-05 <7>	Pulse Train Input Minimum Frequency	Sets the minimum frequency detected by the pulse train input. Enabled when E5-00 = 0, 1, 2.	Default: 0.5 Hz Min.: 0.1 Hz Max.: 1000.0 Hz
E5-06 <4> <7>	Pulse Train Monitor Selection	Sets the function of pulse train output terminal MP 0 : Frequency Command 1 : Output Frequency 2 : Soft Starter Output Frequency 3 : PID Feedback Value 4 : PID Target Value	Default: 0 Range: 0 to 4
E5-07 <4> <7>	Pulse Train Monitor Scaling	Sets the pulse train output frequency when the specified monitor item is at 100%.	Default: 1440 Hz Min.: 100 Hz Max.: 32000 Hz
E5-08 <7>	Terminal RP Function Selection	0 : Pulse train input 1 : PWM signal input	Default: 0 Min.: 0 Max.: 1
E5-09 <4> <7>	Average PWM Signal Times	1 to 100 times	Default: 1 Min.: 1 Max.: 100
E5-10	PWM Signal Cycle	1 to 999 ms	Default: 100 ms

Parameter	Name	Description	Setting Range
<7>			Min.: 1 ms Max.: 999 ms
E6: Optional Communication Card Settings			
E6-06	Drive Station Address	Sets the drive station address.	Default: 1 Range: 1 to 31
E6-07	RS-485 Communication Baud Rate Setting	Sets the baud rate for terminals SG(+) and SG(-) of RS-485 communication. 0: 1200 bps (bit/sec) 1: 2400 bps 2: 4800 bps 3: 9600 bps 4: 19200 bps 5: 38400 bps 6 : 57600 bps 7 : 76800 bps 8 : 115200 bps	Default: 3 Range: 0 to 8
E6-08	RS-485 Communication Parity Selection	Selects the communication parity for terminals SG(+) and SG(-) of RS-485 communication. 0: 8, N, 2 (Modbus RTU) 1: 8, N, 1 (Modbus RTU) 2: 8, E, 1 (Modbus RTU) 3: 8, O, 1 (Modbus RTU) 4: 8, N, 2 (Modbus ASCII) 5: 8, N, 1 (Modbus ASCII) 6: 8, E, 1 (Modbus ASCII) 7: 8, O, 1 (Modbus ASCII) 8: 7, N, 2 (Modbus ASCII) 9: 7, N, 1 (Modbus ASCII) 10: 7, E, 1 (Modbus ASCII) 11: 7, O, 1 (Modbus ASCII)	Default: 1 Range: 0 to 11
E6-09	Communication Error Detection Time	Determines the detection time to trigger the communication error. (This function is disabled when set to 0)	Default: 0.0 s Range: 0.0 to 10.0 s
E6-10	Transmit Wait Time	Sets the wait time between sending and receiving data.	Default: 5ms Range: 5 to 65 ms
E6-11	Drive Operation During Communication Error	0 : Display CE Alarm Only. Drive continues operation. 1 : Display CE Fault. Drive coasts to stop.	Default: 0 Range: 0 to 1
E6-12	Communication	0 : No save	Default: 1

Parameter	Name	Description	Setting Range
	Frequency Command Store Selection	1 : Save	Min. : 0 Max. : 1
E6-13	Communication Frequency Command	MODBUS Communication Frequency Command Store value	Default:: 0.00Hz Min: 0.00Hz Max: 400.00Hz
Group P, Protections			
P1: Motor Protection Function			
P1-00	Motor Protection Function Selection	0 : Disabled (Motor Overload Protection Disabled) 1 : General-Purpose Motor (Standard Motor) 2 : Drive Dedicated Motor (Constant Torque Range 1 : 10) 3 : Vector Motor (Constant Torque Range 1 : 100) Sets 0 (disabled) when using one drive to run more than one motor. Install an overload relay between the drive and each motor.	Default: 0 Range: 0 to 3
P1-01	Motor Overload Protection Time	Sets the time for the drive to shut down on motor overload.	Default: 1.0 minute Min.: 0.1 minutes Max.: 5.0 minutes
P2: Momentary Power Loss			
P2-00	Momentary Power Loss Operation Selection	0 : Disabled (Default) 1 : Recover if CPU Has Power 2 : KEB function if CPU Has Power 3 : Ramp to Stop with KEB Deceleration	Default: 0 Range: 0, 1, 2, 3
P2-01	Minimum Baseblock (bb) Time	Sets the minimum baseblock time when power is restored right after a momentary power loss. This determines the time the drive waits for the residual voltage in the motor to dissipate. Increase this value if overcurrent or overvoltage occurs at the beginning of Speed Search and DC Braking.	Default: Determined by o2-03, A1-06 Min.: 0.1 s Max.: 5.0 s
P2-03	Uv (Undervoltage) Detection Level	Sets the voltage level of undervoltage detection or KEB function activation.	Default: Determined by d1-00, o2-03 Min.: 150V Max.: 210V <3>
P2-04	KEB Deceleration	Sets the time to decelerate during KEB function.	Default: 0.0 s

Parameter	Name	Description	Setting Range
	Time		Min.: 0.0 s Max.: 6000.0 s
P2-05	Acceleration Time after KEB	Sets the time to reaccelerate from the speed when KEB function was deactivated to the set frequency command (operation frequency before power loss). When set to 0.0 s, the drive will accelerate to the previously active frequency according to the active acceleration time set by any of C1-00, C1-02, C1-04 or C1-06.	Default: 0.30 s Min.: 0.00s Max.: 6000.0s
P2-07	KEB Detection Time	Sets the minimum duration of KEB operation after activation. KEB function will operate according to this detection time even if power recovers within this duration.	Default: 50 ms Min.: 0 ms Max.: 2000 ms
P2-08	Voltage Target During KEB	Sets the target value for the main circuit DC voltage or to deactivate KEB.	Default: Determined by d1-00 Min.: 150V Max.: 400V <3>
P2-09	KEB Method Selection	0 : KEB Operation Method 1 1 : KEB Operation Method 2 2 : KEB Operation Method 3	Default: 0 Range: 0, 1, 2
P2-10	Automatic voltage regulation (AVR)	0 : AVR is disabled 1 : AVR is enabled	Default: 1 Range: 0, 1
P3: Stall Prevention			
P3-00	Stall Prevention during Acceleration	0 : Disabled 1 : Enabled the value set in P3-01. Acceleration stops when the output current exceeds the value set in P3-01. Acceleration continues when the output current drops 15% below the value set in P3-01.	Default: 1 Range: 0, 1
P3-01	Stall Prevention Level during Acceleration	Sets the output current level to activate the Stall Prevention function during acceleration.	Default: Determined by A1-06 Min.: 0% Max.: 180%
P3-02	Stall Prevention Limit during Acceleration	Sets the lower limit of Stall Prevention in the constant power range as a percentage of the drive rated output current.	Default: 50% Min.: 0 % Max.: 100 %
P3-03	Stall Prevention during	0 : Disabled The drive decelerates according to the set	Default: 1 Range: 0, 1

Parameter	Name	Description	Setting Range
	Deceleration	deceleration time 1 : Enabled (Without Braking Resistor)	
P3-04	Stall Prevention Level during Deceleration	Sets the voltage level to activate the Stall Prevention function during deceleration.	Default: <8> Min.: 330V Max.: 410V <3>
P3-05	Stall Prevention during Run	0 : Disabled 1 : Enabled (Deceleration Time 1) 2 : Enabled (Deceleration Time 2)	Default: 1 Range: 0, 1, 2
P3-06	Stall Prevention Level during Run	Sets the current level to activate the Stall Prevention function during run.	Default: Determined by A1-06 Min.: 30% Max.: 180%
P4: Frequency Detection			
P4-00	Frequency Detection Level	Sets the detection level and width for the multi-function output terminal.	Default: 30.0 Hz Min.: 0.0 Hz Max.: Determined by d1-02, L2-00
P4-01	Frequency Detection Width		Default: 2.0 Hz Min.: 0.1 Hz Max.: 25.5 Hz
P4-02	Frequency Command Loss Detection Selection	Sets the drive operation when a frequency command loss is detected. 0: Drive Stop 1: Continue operation according to the setting in P4-03.	Default: 0 Range: 0, 1
P4-03	Frequency Command at Frequency Command Loss	Sets the frequency command level at which the drive runs when detecting a frequency command loss and when L4-02 is set to 1. Sets the value as a percentage of the maximum output frequency set in d1-02. (Sets the value as a percentage of the motor 2 maximum output frequency set in d1-13.)	Default: 80 % Min.: 0.0 % Max.: 100.0 %
P4-04	Frequency Command Loss Detection Time	When the frequency command falls below 90% of the command within this detection time, the frequency command loss will be detected.	Default: 20 ms Min.: 20 ms Max.: 400 ms
P4-05	Brake control release frequency	Setting brake control release frequency range	Default: 0.00Hz Min.: 0.00Hz Max.: 20.00Hz
P4-06	Brake control action frequency	Setting Brake control action frequency range	Default: 0.00Hz Min.: 0.00Hz

Parameter	Name	Description	Setting Range
			Max.: 20.00Hz
P5: Fault Restart			
P5-00	Number of Auto Restart Attempts	Sets the number of times to automatically attempt to restart the drive when detecting GF, OVA, OVD, OVC, OCA, OCD, OCC, OH, OL1, OL2, OT1, OT2, PF and LF1.	Default: 0 Min.: 0 Max.: 10
P5-01	Auto Restart Fault Output Operation	0 : Fault Output Disabled 1 : Fault Output Enabled	Default: 0 Range: 0, 1
P5-02	Fault Restart Interval Time	Sets the amount of time between restart attempts.	Default: 10.0 s Min.: 0.5 s Max.: 600.0 s
P6: Overtorque / Undertorque Detection			
P6-00	Overtorque / Undertorque Detection Selection 1	Sets the operation when the motor current or torque exceeds the P6-01 level for longer than the time set to P6-02. 0 : Disabled 1 : Overtorque Alarm at Speed Agree 2 : Overtorque Alarm at Run 3 : Overtorque Fault at Speed Agree 4 : Overtorque Fault at Run 5 : Undertorque Alarm at Speed Agree 6 : Undertorque Alarm at Run 7 : Undertorque Fault at Speed Agree 8 : Undertorque Fault at Run	Default: 0 Range: 0 to 8
P6-01	Overtorque / Undertorque Detection Level 1	Sets the level for overtorque/undertorque detection 1.	Default: 150% Min.: 0 % Max.: 300 %
P6-02	Overtorque / Undertorque Detection Time 1	Sets the time for overtorque/undertorque detection 1.	Default: 0.1 s Min.: 0.0 s Max.: 10.0 s
P6-06	Mechanical Weakening Detection Operation	Sets the speed range to detect mechanical weakening and the operation when detected. 0 : Disabled 1 : Continue Operation if the Speed (Signed) is above P6-07 2 : Continue Operation if the Speed (Unsigned) is above P6-07 3 : Stop Operation if the Speed (Signed) is above P6-07 4 : Stop Operation if the Speed (Unsigned) is above P6-07 5 : Continue Operation if the Speed (Signed) is	Default: 0 Range: 0 to 8

Parameter	Name	Description	Setting Range
		below P6-07 6 : Continue Operation if the Speed (Unsigned) is below P6-07 7 : Stop Operation if the Speed (Signed) is below P6-07 8 : Stop Operation if the Speed (Unsigned) is below P6-07	
P6-07	Mechanical Weakening Detection Speed Level	Sets the speed level for Mechanical Weakening Detection as a percentage of the maximum output frequency.	Default: 110.0% Min.: -110.0% Max.: 110.0%
P6-08	Mechanical Weakening Detection Time	If the condition set in P6-06 lasts the time set in this parameter, Mechanical Weakening is detected.	Default: 0.1 s Min.: 0.0 s Max.: 10.0 s
P6-09	Mechanical Weakening Detection Start Time	Sets the cumulative drive operation time to activate Mechanical Weakening Detection. If U3-00 reaches the value set in this parameter, Mechanical Weakening is detected.	Default: 0 Min.: 0 Max.: 65535
P7: Drive Protection			
P7-00	Input Phase Loss Protection	Enables or disables the input phase loss detection. 0 : Disabled 1 : Enabled	Default: 1 Range: 0, 1
P7-01	Output Phase Loss Protection	Sets the output phase loss detection. 0 : Disabled 1 : Enabled when One Phase is Lost 2 : Enabled when Two Phases are Lost	Default: 0 Range: 0, 1, 2
P7-02	Output Ground Fault Detection	Enables or disables the output ground fault detection. 0 : Disabled 1 : Enabled	Default: 0 Range: 0, 1
P7-03	Heatsink Cooling Fan Operation <6>	Sets the heatsink cooling fan operation. 0 : Enabled when drive is running 1 : Enabled when power supply is On	Default: 0 Range: 0, 1
P7-04	Heatsink Cooling Fan Off-Delay Time	When P7-04=0, sets the cooling fan off-delay time that the drive waits to disabled the cooling fan after run command is released.	Default: 60 s Min.: 0 s Max.: 300 s
P7-05	Ambient Temperature Setting	Sets the ambient temperature. Automatically decreases the drive rated current when the ambient temperature is higher than the temperature specified in drive	Default: 40 °C Min.: -10 °C Max.: 50 °C

Parameter	Name	Description	Setting Range
		specifications.	
P7-06	oL2 Detection Time Reduction at Low Speed	Determines whether to reduce the oL2 (Drive Overload) fault detection time at low speed (below 6 Hz) to prevent premature output transistor failures. 0 : Detection time is not reduced 1 : Detection time is reduced	Default: 0 Range: 0, 1
P7-11	High Current Alarm Setting	Sets the High Current Alarm (HCA) when the output current is too high 0 : Disabled (No Alarm) 1 : Enabled (Alarm)	Default: 0 Range: 0, 1
P7-12	Installation Method Selection	Selects the installation type. The drive overload detection limit will be changed according to the selection. 0 : IP20 Enclosure in a Cabinet 1 : Side-by-Side Mounting 2 : NEMA 1 Enclosure	Default: 0 Range: 0, 1, 2
P7-13	DC Braking Level Setting	Sets the DC braking transistor level.	Default: Determined by d1-00 <3> Range: 360 to 400V <3>
Group n, Special Adjustments			
n1: Hunting Prevention			
n1-00	Hunting Prevention Setting	0 : Disabled 1 : Enabled	Default: 0 Range: 0, 1
n1-01 <4>	Hunting Prevention Gain	If the motor oscillates during light load, gradually increase this value by units of 0.1. If the motor stalls, gradually decrease this value by units of 0.1.	Default: 1.00 Min.: 0.00 Max.: 2.50
Group o, Keypad Function Settings			
o1: Display Setting			
o1-00	Frequency Command Setting/Display Unit	0 : Use units of 0.01 Hz 1 : Use units of 0.01% (100% as maximum output frequency) 2 : Use units of min-1 (automatically calculated by maximum output frequency and number of motor poles)	Default: 0 Range: 0 to 3

Parameter	Name	Description	Setting Range
		3 : Use user-defined units (defined by o1-02 and o1-03)	
o1-02	User-Defined Frequency Command Setting/Display	1 to 60000	Default: Determined by o1-00 Min.: 1 Max.: 60000
o1-03	Frequency Command Setting/Display Decimal Places	0 to 3	Default: Determined by o1-00 Min.: 0 Max.: 3
o2: Multi-Function Selection			
o2-00	LO/RE (LOCAL/REMOTE) Key Function Selection	Enables or disables LO/RE key on the keypad. 0 : Disabled 1 : Enabled Switches between Local and Remote Operation	Default: 1 Range: 0, 1
o2-01	STOP Key Function Selection	Enables or disables the STOP key on the keypad when the drive is controlled from a remote source. 0 : Disabled 1 : Enabled The STOP key always stops drive operation even if the command source is not set to the keypad.	Default: 1 Range: 0, 1
o2-03	Drive Capacity Selection	Set this parameter after replacing the terminal block or drive modules.	Default: <2> Determined by drive capacity
o2-04 <8>	ENTER Key Function During Frequency Command Setting	0 : ENTER Key Required 1 : ENTER Key Not Required After 5 second, the frequency is automatically setting. When entering a frequency command, the output frequency changes immediately by UP or DOWN key 2 : ENTER Key Not Required After 1 second, the frequency is automatically setting	Default: 0 Range: 0, 1,2
o2-05	Action Select When LCM Keypad Disconnection	0 : Disabled 1 : Enabled	Default: 0 Range: 0, 1
o2-06	Operation	0 : Forward	Default: 0

Parameter	Name	Description	Setting Range
	Direction at Power Up when Using Keypad	1 : Reverse This parameter is enabled only when the keypad is selected as the Run command source.	Range: 0, 1
o4: Maintenance Settings			
o4-00	Cumulative Operation Time Setting	Sets the initial value by 10 hours to start keeping track of cumulative operation time.	Default: 0 h Min.: 0 h Max.: 6000 h
o4-01	Retain		
o4-02	Cooling Fan Operation Time Setting	Sets the initial value to start keeping track of cumulative fan operation time. View the cumulative fan operation time in U3-01.	Default: 0 h Min.: 0 h Max.: 6000 h
o4-06	U2 Reset Setting	Resets the data for U2-□□ (Fault Information) as these data will not be reset by A1-03 (Reset). 0 : Disabled 1 : Enabled	Default: 0 Range: 0, 1
o4-07	kWh Monitor Initialization	0 : U3-08 and U3-09 monitor data is not reset when the drive is initialized. 1 : U3-08 and U3-09 monitor data is reset when the drive is initialized.	Default: 0 Range: 0, 1
Group t, Auto-Tuning			
t1: IM Motor Auto-Tuning			
t1-01	Auto-Tuning Method Selection	0 : Rotational Auto-Tuning 1 : Stationary Auto-Tuning 2 : Stationary Auto-Tuning for Line-to-Line Resistance	Default: 0 Range: 0, 1, 2
t1-02	Motor Output Power	Sets the motor rated output power in kW units. Note: 1HP (Horse Power) = 0.746kW	Default: <2> Min.: 0.00 kW Max.: 650.00 kW
t1-03	Motor Rated Voltage	Sets the motor rated voltage according to the motor nameplate.	Default: 200.0 V Min.: 0.0 V Max.: 255.0 V <3>
t1-04	Motor Rated Current	Sets the motor rated current according to the motor nameplate.	Default: <2> Min.: 10% of drive rated current Max.: 200% of drive rated current
t1-05	Motor Base Frequency	Sets the motor base frequency according to the motor nameplate.	Default: 50.0 Hz Min.: 0.0 Hz

Parameter	Name	Description	Setting Range
			Max.: 400.0 Hz
t1-06	Number of Motor Poles	Sets the number of motor poles according to the motor nameplate.	Default: 4 Min.: 2 Max.: 48
t1-07	Motor Base Speed	Sets the motor base speed according to the motor nameplate.	Default: <2> Min.: 0 rpm Max.: 24000 rpm
t1-09	Motor No-Load Current (Stationary Auto-Tuning)	Sets the no-load current for the motor. After the motor output power and rated current are set in t1-02 and t1-04, this parameter will automatically display the no-load current of a standard motor. The no-load current must be entered according to the motor test report.	Default: Determined by o2-03 · A1-06 Min.: 0 A Max.: t1-04
t1-12	Motor Auto-Tuning Setting	Enables or disables Auto-Tuning when A1-02=0 to 3 0 : Disabled 1 : Enabled	Default: 0 Range: 0, 1

Parameter	Name	Description	Unit
Group U, Monitor Settings			
U1: Status Monitors			
U1-00	Control Method	0: V/F Control 1: Sensorless Voltage Vector Control	-
U1-01	Frequency Command	Displays the frequency command. (Display units are defined by o1-00)	-
U1-02	Output Frequency	Displays the output frequency. (Display units are defined by o1-00)	-
U1-03	Output Current	Displays output current.	0.01A
U1-04	Motor Speed	Displays the motor speed.	-
U1-05	Output Voltage Command	Displays the drive output voltage command.	0.1V
U1-06	Main circuit DC Voltage	Displays the main circuit DC voltage.	0.1V
U1-07	Output Power	Displays the internal output power calculated by the drive.	<50HP : 0.001kW >50HP : 0.01kW
U1-09	Input Terminal Status	Displays the status of the input terminal. U1 - 09= C 1111111 The following indicate each digit from right to left. 1:Digital Input 1 (S1 enabled) 1:Digital Input 2 (S2 enabled) 1:Digital Input 3 (S3 enabled) 1:Digital Input 4 (S4 enabled) 1:Digital Input 5 (S5 enabled) 1:Digital Input 6 (S6 enabled) 1:Digital Input 7 (S7 enabled)	-
U1-10	Output Terminal Status	Displays the status of the output terminal. U1 - 10= o 111 The following indicate each digit from right to left. Multi-Function Terminal Output (terminal R1A/R1B-R1C) Multi-Function Terminal Output (terminal R2A –R2C) Multi-Function Photocoupler Output 1 (terminal D1)	-
U1-11	Drive Operation Status	Displays the status of the drive operation. U1-11=11111111 The following indicate each digit from right to left. 1:During Run 1:During Zero Speed Holding	-

Parameter	Name	Description	Unit
		1:During Reverse 1:During Fault Reset Signal Input 1:During Speed Agree 1:Drive Ready 1:During Alarm Detection 1:During Fault Detection	
U1-12	Terminal A1 Input Voltage	Displays the terminal A1 input voltage.	0.1%
U1-13	Terminal A2 Input Voltage	Displays the terminal A2 input voltage.	0.1%
U1-14	Output Frequency After Soft Start	Display the output frequency after soft start	0.01Hz
U1-15	Input Pulse Monitor	Displays the frequency to pulse input.	1Hz
U1-16	Software Version	Displays the software version.	-
U2: Fault Information			
U2-00	Current Fault	Displays the current fault.	-
U2-01	1 st Most Recent Fault	Displays the first most recent fault.	-
U2-02	2 nd Most Recent Fault	Displays the second most recent fault.	-
U2-03	3 rd Most Recent Fault	Displays the third most recent fault.	-
U2-04	4 th Most Recent Fault	Displays the fourth most recent fault.	-
U2-05	Frequency Command at 1 st Most Recent Fault	Displays the frequency command at the first most recent fault.	-
U2-06	Output Frequency at 1 st Most Recent Fault	Displays the output frequency at the first most recent fault.	-
U2-07	Output Current at 1 st Most Recent Fault	Displays the output current at the first most recent fault.	0.01A
U2-08	Motor Speed at 1 st Most Recent Fault	Displays the motor speed at the first most recent fault.	-
U2-09	Output Voltage command at 1 st Most Recent Fault	Displays the output voltage command at the first most recent fault.	0.1V
U2-10	Main Circuit DC	Displays the main circuit DC voltage at the first most recent	0.1V

Parameter	Name	Description	Unit
	Voltage at 1 st Most Recent Fault	fault.	
U2-13	Input Terminal Status at 1 st Most Recent Fault	Displays the input terminal status at the first most recent fault. (Same status display as U1-09)	-
U2-14	Output Terminal Status at 1 st Most Recent Fault	Displays the output terminal status at the first most recent fault. (Same status display as U1-10)	-
U2-15	Operation Status at 1 st Most Recent Fault	Displays the operation status at the first most recent fault. (Same status display as U1-11)	-
U2-17 <7>	Cumulative Power-on Time at 1 st Most Recent Fault	Displays the cumulative power-on time at the first most recent fault	1h
U2-18	Cumulative Operation Time at 1 st Most Recent Fault	Displays the cumulative operation time at the first most recent fault	1h
U2-19	Frequency Command at 2 nd Most Recent Fault	Displays the frequency command at the second most recent fault.	-
U2-20	Output Frequency at 2 nd Most Recent Fault	Displays the output frequency at the second most recent fault.	-
U2-21	Output Current at 2 nd Most Recent Fault 2 nd	Displays the output current at the second most recent fault.	0.01A
U2-22	Motor Speed at 2 nd Most Recent Fault	Displays the motor speed at the second most recent fault.	-
U2-23	Output Voltage command at 2 nd Most Recent Fault	Displays the output voltage command at the second most recent fault.	0.1V
U2-24	Main Circuit DC Voltage at 2 nd Most Recent Fault	Displays the main circuit DC voltage at the second most recent fault.	0.1V
U2-27	Input Terminal Status at 2 nd Most Recent Fault	Displays the input terminal status at the second most recent fault. (Same status display as U1-09)	-
U2-28	Output Terminal Status at 2 nd Most	Displays the output terminal status at the second most recent fault. (Same status display as U1-10)	-

Parameter	Name	Description	Unit
	Recent Fault		
U2-29	Operation Status at 2 nd Most Recent Fault	Displays the operation status at the second most recent fault. (Same status display as U1-11)	-
U2-31 <7>	Cumulative Power-on Time at 2 nd Most Recent Fault	Displays the cumulative power-on time at the second most recent fault	1h
U2-32	Cumulative Operation Time at 2 nd Most Recent Fault	Displays the cumulative operation time at the second most recent fault	1h
U2-33	Current Alarm	Displays the current alarm.	-
U2-34	1 st Most Recent Alarm	Displays the first most recent alarm.	-
U2-35	2 nd Most Recent Alarm	Displays the second most recent alarm.	-
U2-36	3 rd Most Recent Alarm	Displays the third most recent alarm.	-
U2-37	4 th Most Recent Alarm	Displays the fourth most recent alarm.	-
U3: Maintenance Monitors			
U3-00	Cumulative Drive Power-on Time	Displays the cumulative power-on time for the drive. The maximum number displayed is 60000, after which the value will be counted from 0.	1h
U3-01	Cumulative Cooling Fan Operation Time	Displays the cumulative operation time for the cooling fan. The initial value is determined by o4-02. The maximum number displayed is 60000, after which the value will be counted from 0.	1h
U3-02	Cumulative Drive Operation Time	Displays the cumulative operation time for the drive. The initial value is determined by o4-00. The maximum number displayed is 60000, after which the value will be counted from 0.	1h
U3-06	Heatsink Temperature	Displays the heatsink temperature.	1°C
U3-07 <7>	LED Detection	Detects LED keypad working properly.	-
U3-10	Peak Hold Current	Displays the peak current value during operation	0.01A
U3-11	Peak Hold Output Frequency	Displays the output frequency when the peak current displayed in U3-10 occurred.	-

Parameter	Name	Description	Unit
U3-12	Motor Overload Estimate (oL1)	Displays the value of the motor overload detection accumulator. An oL1 will be triggered when reaching 100%.	1%
U3-13	Frequency Command Source Selection	Displays the source for the frequency command as XY-nn. X: Command Used 1: Command 1 2: Command 2 Y-nn: Frequency Command Source 0-01: Keypad 1-01: Analog input (Terminal AI 1) 1-02: Analog input (Terminal AI 2) 2-02 to 2-16: Multi-step speed command 2-17: Jog frequency command 3-01: PID frequency command 4-01: Terminal UP/ DOWN 5-01: Modbus communication 6-01: Pulse train command 7-00 ~ 7-16 : Automatic operation command	-
U3-14	Run Command Source Selection	Displays the source for the frequency command as XY-nn. XY-nn=00-00: Local X: Command Used 1: Command 1 2: Command 2 Y-nn: Command Source 0-00: Keypad 0-01: Control Circuit Terminal (Sequence Control Input) 0-02: Modbus communication	-
U3-17	Drive Overload Estimate (oL2)	Displays the value of the drive overload detection accumulator. An oL2 will be triggered when reaching 100%.	1%
U4: PID Monitors			
U4-00	PID Feedback	Displays the PID feedback value as a percentage of the maximum output frequency.	0.01%
U4-01	PID Input	Displays the PID input value as a percentage of the maximum output frequency.	0.01%
U4-02	PID Output	Displays the PID output value as a percentage of the maximum output frequency.	0.01%
U4-03	PID Target	Displays the PID target value as a percentage of the maximum output frequency.	0.01%
U4-04	PID Differential Feedback	Displays the difference of both feedback values when 10 is set to both E3-01 and E3-07.	0.01%

Parameter	Name	Description	Unit
U4-05	PID Feedback 2	Displays the adjusted feedback value if differential feedback is used (U4-00 to U4-04) The value in U4-00 and U4-05 will be the same if differential feedback is not used.	0.01%
U4-06	PG Rotating Direction	0: Correct PG wiring 1: The speed command is opposite to the PG feedback direction. Please check the wiring.	-
U4-08 <7>	PID Output 2	Displays the PID output 2 value as a percentage of the maximum output frequency.	0.01%

<1> The default is determined by the drive capacity, control method and ND/HD mode.

<2> Refer to user manual for details. <http://www.liteon-ia.com.tw/ENG/download.php>

<3> Double the value for 440V class AC drives.

<4> The parameter can be set during run.

<5>The maximum of parameter setting by d1-02 (maximum output frequency) and L2-00 (frequency command limit) will be changed

<6> Contact the local distributor for any malfunction.

<7> Digital input terminal S7 is set to 74

<8> This functional software version V1.10 open.

*** The content of parameters will make some adjustments. Please refer to the manual on the website. <http://www.liteon-ia.com/ENG/download.php>**

Chapter 6 | Troubleshooting

6.1 Alarm and Fault Displays.

The cause of alarm or fault have been closed out, part of alarm display code will be automatically clear

Table 6.1 Alarm and Fault Displays, Causes, and Possible Solutions

Keypad Display	Fault Name	Cause	Possible Solution
EFO	Retain		
EF1 to EF7	External Fault (Input Terminal S1 to S7)	<ol style="list-style-type: none"> 1. An external device tripped an alarm 2. Incorrect wiring 3. Multi-function input wiring is not correct 	<ol style="list-style-type: none"> 1. Remove the cause of the external fault then reset the multi-function input. 2. Confirm if the signal lines is properly connected to the terminals assigned for external fault detection (E1-□□ = 23 to 38) 3. Confirm if E1-□□=23 to 38 is set to the unused terminals.
FbH	<p>PID Feedback High</p> <p>PID feedback input is greater than the detection level set to b5-22 for longer than the detection time set to b5-23</p>	<ol style="list-style-type: none"> 1. b5-22 and b5-23 inappropriate setting 2. PID feedback wiring incorrect 3. Feedback sensor malfunction 4. Feedback input circuit malfunction 	<ol style="list-style-type: none"> 1. Confirm b5-22 and b5-23 settings 2. Correct the wiring 3. Replace the sensor if it is damaged 4. Replace the PCB or drive. Contact the local distributor.
FbL	<p>PID Feedback Low</p> <p>When the PID feedback detection is enabled in b5-11, a FbL will be triggered while the PID feedback falls below the level set to b5-12 for longer than the time set</p>	<ol style="list-style-type: none"> 1. Inappropriate setting in b5-12 and b5-13 2. Incorrect PID feedback wiring 3. Feedback sensor malfunction 4. Incorrect feedback input circuit 	<ol style="list-style-type: none"> 1. Correct b5-12 and b5-13 settings 2. Correct the wiring 3. Replace the sensor if it is damaged 4. Contact the local distributor to replace the board or the drive.

Keypad Display	Fault Name	Cause	Possible Solution
	to b5-13.		
oH	Heatsink Overheat Heatsink temperature over 90 to 100°C (Overheat level is determined by rating of the drive)	1. Ambient temperature is too high 2. Internal cooling fan stopped operating 3. Bad air flow due to insufficient room.	1. Check the temperature surrounding the drive a. Improve the air flow inside the enclosure panel b. Install an air conditioner or fan to cool the environment c. Remove any possible source of heat 2. Measure the output current a. Reduce the load b. Lower setting in C6-00 (Carrier Frequency Option) 3. Replace the cooling fan
oH1	Motor Overheat The temperature signal from motor temperature sensor via the terminal MT exceeded the overheat detection level of the drive.	1. Incorrect motor temperature input (terminal MT) wiring 2. Fault on the machinery (e.g., machinery is locked up) 3. Motor overheat	1. Correct the wiring for terminal MT. 2. Check the machinery status 3. Check the load, acceleration / deceleration time and cycle time a. Reduce the load. b. Increase the C1-00 to C1-07 (Acc./Dec. Time) settings c. Adjust d1-02 to d1-11 (V/F Characteristics)
ot1	Overtorque Detection 1 The current has exceeded the torque level set to P6-01 for longer than the time set to P6-02	1. Incorrect parameter settings 2. Malfunction on machinery	1. Reset P6-01 and P6-02 2. Check machinery and load status
ov	Overvoltage Voltage in the DC bus exceeded the overvoltage detection level 1.200 V class: 410 V 2.400 V class: 820 V	1. Drive input power has surge voltage entering 2. Machinery output short circuit 3. Ground fault in the output circuit causes the DC bus capacitor to overcharge 4. Electrical signal	1. Install a DC link choke Voltage surge can result from a thyristor convertor and phase advancing capacitor using the same input power supply 2. Check the motor power cable, relay terminals and motor terminal box 3. Correct grounding shorts and

Keypad Display	Fault Name	Cause	Possible Solution
		<p>interference causes drive malfunction</p> <p>5. PG cable is disconnected</p> <p>6. Incorrect PG cable wiring</p> <p>7. PG encoder wiring is interference by electrical signal</p>	<p>reapply power</p> <p>4. Check the solutions for interference suppression</p> <p>»Check the control circuit lines, main circuit lines and grounding wiring.</p> <p>»If the MC is the source of interference, connect a suppressor to it.</p> <p>5. Reconnect the cable</p> <p>6. Correct the wiring</p> <p>7. Separate the wiring from the source of the electrical signal interference. It is usually the output lines from the drive</p>
Uv	<p>Undervoltage</p> <p>1.Voltage in the DC bus fell below the undervoltage detection level (P2-03)</p> <p>2.200 V class: 190 V</p> <p>3.400 V class: 380 V</p>	<p>1. Input power phase loss</p> <p>2. Loose wiring terminals of drive input power</p> <p>3. Problem with the voltage from the drive input power</p> <p>4. The drive main circuit capacitors are weakened.</p> <p>5. The contactor or relay on the soft-charge bypass circuit is damaged</p>	<p>1. Correct the drive input power wiring</p> <p>2. Tighten the terminals</p> <p>3. Check the voltage</p> <p>a. Adjust the voltage according to the drive input power specifications</p> <p>b. Check the main circuit magnetic contactor if there is no problem with the power supply</p> <p>4&5. Turn on and turn off the power to see if any problem occurs</p> <p>Replace either the entire drive or the control board if the problem continues to occur. Contact the local distributor for more information.</p>
Ut1	<p>Undertorque Detection</p> <p>1 The current has dropped below the torque detection level set to P6-01 for longer than the time set to P6-02</p>	<p>1. Incorrect parameter settings</p> <p>2.Malfunction on machinery side</p>	<p>1. Reset P6-01 and P6-02</p> <p>2. Ensure there is no problem on the machinery side.</p>

Keypad Display	Fault Name	Cause	Possible Solution
UL	Mechanical Weakening Detection for Undertorque Undertorque in the conditions set to P6-06	Undertorque in the conditions set to P6-06	Check the condition of mechanical weakening
oL	Mechanical Weakening Detection for Overtorque Overtorque in the conditions set to P6-06	Overtorque in the conditions set to P6-06	Check the condition of mechanical weakening
bb	Baseblock Drive output interrupted by an external baseblock signal	An external baseblock signal was input via one of the multi-function input terminals (S1 to S)	Check baseblock signal input timing and external sequence
oH2	Drive Overheat Warning Drive Overheat Warning input via a multi-function input terminal (S1to S7) when E1-□□= 40	An overheat warning in the drive was triggered by an external device	1. Search the device which caused the overheat warning. Remove the cause of the problem. 2. Reset Drive Overheat Warning input at the assigned multi-function input terminal (S1to S7)
HCA	Current Alarm Drive current exceeded the level of over current warning (150% of the rated current)	1. The load is too heavy 2. Deceleration and acceleration times are too short 3.The drive is attempting to run a motor greater than the maximum allowable capacity, or a special-purpose motor is being used 4.The current level went up because of Speed Search while attempting to perform a fault restart or after a momentary power loss	1. Reduce the load or use a drive of higher rating 2. Calculate the torque required during acceleration and the inertia »Take the following steps if the torque level is not right for the load · Increase the settings for acceleration and deceleration time (C1-00 to C1-07) · Use a drive of higher rating 3. Check the motor capacity · Make sure the motor capacity is right for the drive rating. 4. During a momentary power loss or an attempt to reset a fault,

Keypad Display	Fault Name	Cause	Possible Solution
			the alarm is displayed. However, there is no need to take any action because the fault display will disappear shortly
DNE	Driver Enable	<ol style="list-style-type: none"> 1. Multi-function contact input is set to 69/169, but the contact input status is incorrect 2. The multi-function contact input is incorrect 	<ol style="list-style-type: none"> 1. Multi-function contact input is set to 69 and switched on. 2. Multi-function contact input is set to 169 and switched off
AnL	Simulation A2 input signal is lost	<ol style="list-style-type: none"> 1. Simulation A2 input signal is lost 	<ol style="list-style-type: none"> 1. Check the simulation signal wiring 2. Check the E3-10 parameter settings
ES	Emergency Stop	<ol style="list-style-type: none"> 1. Emergency stop is turned on (P2-11) before the power off, when the DC bus voltage is lower than P2-06 2. Multi-function contact input is set to 21/121, but the contact input is switched on 	<ol style="list-style-type: none"> 1. Turn off the emergency stop function P2-11, or adjust P2-06 settings Level 2. Confirm the multi-function contact input function set and terminal status

6.2 Fault Detection

Table 6.2 Fault Displays, Causes, and Possible Solution

Keypad Display	Fault Name	Cause	Possible Solution
GF	Ground Fault	Output power cable is damaged	Check and replace output power cable
oVA、 oVd、 oVC、 oVAH、 oVdH、 ovCH	Overvoltage (Acceleration, Deceleration and Constant Speed) The main circuit DC voltage exceeded the overvoltage detection level 200V class: 410V 400 V class: 820 V	1. Regenerative energy is flowing from the motor into the drive because the deceleration time is too short 2. The motor overshoot the speed reference because the acceleration time is too short 3. Excessive braking load 4. Surge voltage entering from the drive input power 5. Motor short-circuited Ground fault current charges the drive main circuit capacitor. 6. Improper parameter settings for Speed Search (including Speed Search after a fault restart and after a momentary power loss) 7. Drive input voltage is too high 8. The braking transistor or braking resistor are wired incorrectly 9. PG cable is disconnected 10. PG cable wiring is incorrect 11. PG encoder wiring has interference of electrical signal 12. Electrical signal interference causes the drive malfunction	1. Increase the deceleration time settings (C1-01, C1-03, C1-05, C1-07) »Install a braking unit or a dynamic braking resistor »Set P3-03 (Stall Prevention during Deceleration) to 1 (Enabled)(default is 1) 2. Confirm if overvoltage alarm oVA or oVC was triggered during sudden drive acceleration. »Increase the acceleration time »Use S-curve deceleration and acceleration times and increase the value set to C2-01 (S-curve at acceleration end) 3. Install a braking unit or a braking resistor 4. Install a DC reactor »Thyristor convertor and phase advancing capacitor using the same input power supply might cause a voltage surge 5. Check the motor power cable, relay terminals and motor terminal box » Correct grounding shorts and reapply power 6. Adjust parameter settings for Speed Search (group b3) »Proceed Auto-Tuning for line-to-line resistance 7. Check the voltage

Keypad Display	Fault Name	Cause	Possible Solution
		13. Incorrect inertia setting of the load 14. Motor hunting occurs	»Lower drive input power voltage within the range listed in the drive specifications 8. Check the wiring of the braking resistor and braking unit »Correct the wiring 9. Tighten the terminal or replace the damaged cable 10. Correct the wiring 11. Separate the PG wiring from the source of the electrical signal interference (drive output cable) 12. Check the solutions for interference suppression »Check the wiring of control circuit I, main circuit and grounding. 13. Check the load inertia settings when using KEB, or Stall Prevention during deceleration 14. Adjust the parameters to suppress hunting »Adjust n1-01 (Hunting Prevention Gain)
oCA, oCd, oCC	Overcurrent (Acceleration, Deceleration and Constant Speed)	1. The motor insulation is damaged or the motor is overheated 2. Grounding problem caused by damaged motor cable 3. The drive is damaged 4. The load is too heavy 5. Settings for acceleration or deceleration time is too short 6. The drive is running a special purpose motor or a motor larger than the drive rated capacity 7. A magnetic contactor (MC) on the output side of	1. Check the insulation resistance 2. Check the motor power cable 3. Check the resistance between the cable and the terminal. 4. Short circuit on drive output side or grounding causes register damage. 5. Measure the current flowing into the motor 5. Check the motor capacity 6. Calculate the torque required during acceleration according to the load inertia and acceleration time. If the required torque is insufficient, check the motor capacity. 7. Install a sequence controller

Keypad Display	Fault Name	Cause	Possible Solution
		<p>the drive has turned on or off</p> <p>8. V/F set incorrectly</p> <p>9. Excessive torque compensation</p> <p>10. Electrical signal interference causes drive malfunction</p> <p>11. Overexcitation gain is set too high</p> <p>12. Run command was applied while motor was coasting</p> <p>13. Incorrect motor code</p> <p>14. The motor does not match the drive control method</p> <p>15. The motor cable is too long</p>	<p>to ensure the MC does not open or close when the drive is outputting voltage.</p> <p>8. Check the ratios between the frequency and voltage set by V/F.</p> <p>9. Adjust d1-02 to d1-11 (or d1-13 to d1-22 for motor 2)</p> <p>10. Check the amount of torque compensation</p> <p>11. Find out possible solutions to suppress the electrical signal interference</p> <p>11. Check if the fault occurs frequently with overexcitation function operation</p> <p>12. Enable Speed Search via multi-function input terminal</p> <p>13. Confirm the amount of torque boost °</p> <p>14. Confirm the status of filter °</p> <p>15. Confirm the fault occurred in the over-excitation</p> <p>17. Check the control method (A1-02)</p> <p>18. Use a larger drive</p>
SC、SC1、SC2、SC3	IGBT Fault or Output Short Circuit	<p>1. Motor has been damaged due to the motor insulation weakened or overheat</p> <p>2. The cable is damaged</p> <p>3. Hardware fault</p> <p>4. The drive is damaged</p>	<p>1. Replace the motor or check the motor insulation resistance</p> <p>2. Repair any short circuits and check the motor power cable</p>
EFO	Retain		
EF1to EF7	External Fault (Input Terminal S1 to S7)	<p>1. An external device tripped an alarm</p> <p>2. Incorrect wiring</p> <p>3. Multi-function input wiring is not correct</p>	<p>1. Remove the cause of the external fault then reset the multi-function input.</p> <p>2. Confirm if the signal lines is properly connected to the terminals assigned for external fault detection (E1-□□= 23 to 38)</p> <p>3. Confirm if E1-□□=23 to 38 is set to the unused terminals.</p>

Keypad Display	Fault Name	Cause	Possible Solution
oH	Heatsink Overheat Heatsink temperature over 90 to 100°C (Overheat level is determined by rating of the drive)	1. Ambient temperature is too high 2. Internal cooling fan stopped operating 3. Bad air flow due to insufficient room.	1. Check the temperature surrounding the drive a. Improve the air flow inside the enclosure panel b. Install an air conditioner or fan to cool the environment c. Remove any possible source of heat 2. Measure the output current a. Reduce the load b. Lower setting in C6-00 (Carrier Frequency Option) 3. Replace the cooling fan
oH1	Motor Overheat The temperature signal from motor temperature sensor via the terminal MT exceeded the overheat detection level of the drive.	1. Incorrect motor temperature input (terminal MT) wiring 2. Fault on the machinery (e.g., machinery is locked up) 3. Motor overheat	1. Correct the wiring for terminal MT. 2. Check the machinery status 3. Check the load, acceleration / deceleration time and cycle time a. Reduce the load. b. Increase C1-00 to C1-07 (Acc./Dec. Time) settings c. Adjust d1-02 to d1-11 (V/F Characteristics)
oL	Mechanical Weakening Detection for Overtorque Overtorque in the conditions set to P6-06	Overtorque in the conditions set to P6-06	Check the condition of mechanical weakening
oL1	Motor Overload	1. The load is too heavy 2. The acceleration and deceleration times are too short 3. The motor is driven below the rated speed with a high load 4. Incorrect setting in P1-00 (Motor Protection Function Selection) when running a	1. Check loading capacity » Reduce the load 2. Confirm acceleration and deceleration times » Increase C1-00 to C1-07 parameter settings 3. » Reduce the load » Increase the speed » Either increase the motor capacity or use a

Keypad Display	Fault Name	Cause	Possible Solution
		special motor 5. The voltage determined by the V/F is too high 6. d2-00 (Motor Rated Current) setting incorrect 7. The base frequency is set too low 8. Use one drive to run multiple motors 9. The electrical thermal protection characteristics do not match the motor overload characteristics. 10. The electrical thermal relay operates at the wrong level 11. Motor overheated by overexcitation operations 12. Speed Search related parameters are set incorrectly 13. Power supply phase loss causes output current oscillation.	special-purpose motor if the motor needs to operate at low speeds 4. Set P1-00 to 2. 5. Adjust d1-02 to d1-11 settings (V/F Characteristics) Note: If d1-02 to d1-11 settings are too low, load tolerance at low speeds will be reduced 6. Confirm the motor rated current » Set d2-00 (Motor Rated Current) according to the motor nameplate 7. Confirm the rated frequency showed on the motor nameplate » Set d1-04 (Base Frequency) according to the motor nameplate 8. Set P1-00 (Motor Protection Function Selection) to 0 (Disabled) and install a thermal relay to each motor 9. Confirm characteristics of the motor » Set P1-00 (Motor Protection Function Selection) correctly » Install an external thermal relay 10. Overexcitation increases the motor loss 11. Adjust parameters related to Speed Search » Adjust the b3-01 (Speed Search Operation Current) setting 12. Check the power supply for phase loss
oL2	Drive Overload	1. The load is too heavy 2. The acceleration and deceleration times are too short	1. Check loading capacity » Reduce the load 2. Confirm acceleration and deceleration times

Keypad Display	Fault Name	Cause	Possible Solution
		3. The voltage determined by the V/F is too high 4. The drive capacity is too small 5. The motor is driven below the rated speed with a high load 6. Torque compensation is too high 7. Speed Search related parameters are set incorrectly 8. Power supply phase loss causes output current oscillation	»Increase C1-00 to C1-07 parameter settings 3. Adjust d1-02 to d1-11 settings (V/F Characteristics) Note: If d1-02 to d1-11 settings are too low, load tolerance at low speeds will be reduced 4. Use a larger drive 5. »Reduce the load at low speed » Use a larger drive » Set a lower value to C6-00 (Carrier Frequency) 6. Check the torque compensation » Set a lower value to C3-00 (Torque Compensation Gain) until the current is decreased and the motor does not stall. 7. Adjust parameters related to Speed Search » Adjust b3-01 (Speed Search Operation Current) 8. Check the power supply for phase loss
ot1	Overtorque Detection 1 The current has exceeded the torque level set to P6-01 for longer than the time set to P6-02	1. Incorrect parameter settings 2. Malfunction on the machinery side	1. Reset P6-01 and P6-02 2. Check machinery and load status
Ut1	Undertorque Detection 1 The current has dropped below the torque detection level set to P6-01 for longer than the time	1. Incorrect parameter settings 2. Malfunction on the machinery side	1. Reset P6-01 and P6-02 2. Ensure there is no problem on the machinery side.

Keypad Display	Fault Name	Cause	Possible Solution
	set to P6-02		
UL	Mechanical Weakening Detection for Undertorque Undertorque in the conditions set to P6-06	Undertorque in the conditions set to P6-06	Check the condition of mechanical weakening
Uv1	Undervoltage Detection 1 Voltage in the DC bus fell below the undervoltage detection level (P2-03) during run. · 200 V class: 190 V · 400 V class: 380 V	1. Input power phase loss 2. Loose wiring terminals of drive input power 3. Problem with the voltage from the drive input power 4. The drive main circuit capacitors are weakened. 5. The contactor or relay on the soft-charge bypass circuit is damaged	1. Correct the drive input power wiring 2. Tighten the terminals 3. Check the voltage a. Adjust the voltage according to the drive input power specifications b. Check the main circuit magnetic contactor if there is no problem with the power supply 4. Turn on and turn off the power to see if any problem occurs a. Replace either the entire drive or the control board if the problem continues to occur. Contact the local distributor for more information.
Uv2	Retain		
PF	Input Phase Loss Drive input power has a large imbalance of voltage between phases or has an open phase (Detected when P7-00=1)	1. Phase loss in the drive input power 2. Drive input power terminals has a loose wiring 3. Drive input power voltage has an excessive fluctuation 4. The main circuit capacitors are impaired	1. Check wiring for errors in the main circuit drive input power »Correct wiring 2. Make sure the terminals are tightened correctly »Apply the tightening torque as showed in the manual 3. Confirm the voltage from the drive input power »Apply possible solutions for drive input power stabilization 4. Check drive input power. If

Keypad Display	Fault Name	Cause	Possible Solution
			drive input power seems normal but the alarm continues to occur, replace either the entire drive or the control board. Contact the local distributor for more information.
LF1	Output Phase Loss Phase loss on the drive output side	<ol style="list-style-type: none"> 1. The output cable is not connected 2. The motor winding is impaired 3. The output terminal is loose 4. The rated current of the motor being used is 5% less than the drive rated current 5. An output transistor is impaired 6. A single phase motor is activating 	<ol style="list-style-type: none"> 1. Check the errors for wiring then properly connect the output cable »Correct the wiring 2. Check the resistance which located between motor lines »If the winding is impaired, replace the motor 3. Use tightening torque which showed in the manual in order to fasten the terminal 4. Check motor capacities and the drive 5. The drive cannot run a single phase motor
LF2	Retain		
FbH	PID Feedback High	<ol style="list-style-type: none"> 1. Incorrect parameter settings 2. Incorrect PID feedback wiring 3. Feedback sensor malfunction 	<ol style="list-style-type: none"> 1. Reset b5-22 and b5-23 2. Correct the wiring 3. Check the sensor
FbL	PID Feedback Low	<ol style="list-style-type: none"> 1. Incorrect parameter settings 2. Incorrect PID feedback wiring 3. Feedback sensor malfunction 	<ol style="list-style-type: none"> 1. Reset b5-12 and b5-13 2. Correct the wiring 3. Check the sensor
bUS	Retain		
CE	Modbus Communication Error	<ol style="list-style-type: none"> 1. Incorrect wiring 2. Communication data error caused by noise 	<ol style="list-style-type: none"> 1. Correct the wiring »Check short circuits and disconnected cables, repair if necessary

Keypad Display	Fault Name	Cause	Possible Solution
			2. Check possible solution to suppress the noise
CF	Retain		
Err	Retain		
Sto	Retain		
JoGEr	FJOG/ RJOG Input Error	A FJOG and RJOG Run commands are received at the same time	Check the Run command from the external source for Fjog/Rjog

6.3 Operation Errors

Table 6.3 Error Displays, Causes, and Possible Solutions

Keypad Display	Error Name	Cause	Possible Solution
oPE02	Parameter Range Setting Error	Parameters are set outside of the possible setting range	<ol style="list-style-type: none"> 1. Set the parameters to the proper values 2. Reset the drive
oPE03	Multi-Function Input Selection Error	<ol style="list-style-type: none"> 1. Either of Up command and Down command is not set (E1-□□= 10 or 11) 2. Either of Up command 2 and Down command 2 is not set (E1-□□=12 or 13) 	Properly assign both of the UP and Down commands to the multi-function input terminal.
oPE04	3-Wire Sequence Control Error	Multi-Function input terminals S1 and S2 are assigned to E1-□□= 2 (3-Wire Sequence)	Do not assign multi-function input terminals S1 and S2 to E1-□□= 2 (3-Wire Sequence)
oPE05	Communication Error		
oPE06	Control Method Selection Error	A control method that requires a PG option card (A1-02 = 1, 3, or 5) is selected, but no PG card is installed	Install a PG option card or correct the value set to A1-02
oPE07	Multi-Function Analog Input Selection Error	E3-01 and E3-07 are set to the same value	Set different values to E3-01 and E3-07
oPE08	PID output upper / lower Selection Error	1. b5-05 PID upper limit is less than the lower limit value of b5-20 PID	1. Reset the PID upper / lower limit
oPE09	PID Control Selection Fault (When b5-00 (PID Control Setting)= 1 to 4)	<ol style="list-style-type: none"> 1. Contradictory settings <ul style="list-style-type: none"> · b5-14 (PID Sleep Start Level) is not set to 0.0 · b1-02 (Stopping Method Selection) is set to 2 (DC Braking to Stop) or 3 (Coast to Stop with Timer) 2. L2-01 (Frequency Command Lower Limit)≠0 when b5-00 = 1 or 2 (PID 	<ol style="list-style-type: none"> 1. Correct the parameter setting. 2. Correct the parameter setting. 3. Correct the parameter setting. 4. Correct the parameter setting.

Keypad Display	Error Name	Cause	Possible Solution
		Control Enabled) 3. b5-10 (PID Output Reverse Selection) = 1 (Reverse Enabled) when b5-00 = 1 or 2 4. L2-01 \neq 0 when b5-00 = 3 or 4	
oPE10	V/F Data Setting Error Incorrect d1-02, d1-04, d1-06, d1-08, d1-10 (or d1-13, d1-15, d1-17, d1-19, d1-21) settings	V/F parameters setting incorrect	Correct the setting in d1-02, d1-04, d1-06, d1-08 and d1-10 (or d1-13, d1-15, d1-17, d1-19 and d1-21).
oPE11	Carrier Frequency Setting Error	1. Contradictory settings · C6-03 (Carrier Frequency Proportional Gain) > 6 · C6-02 (Minimum Carrier Frequency) > C6-01 (Maximum Carrier Frequency) Note: If C6-03 \leq 6, the drive operates at C6-01 2. The limit set in C6-00 to C6-03 are contradictory	Correct the parameter setting.
oPE12	Analog Frequency Command Hold Error	When E1-□□=61, there is another E1-□□ is set to 10 to 13, 18 or 53 to 55.	Correct the setting.
oPE13	Main and Alternative Frequency Command Error	When b1-00 and b1-07 are setting the same supply source.	Correct the setting.
oPE14	Incorrect Jump Frequency Setting	The setting does not follow L3-00 \leq L3-01 \leq L3-02	Correct the setting.
oPE15	Retain		
oPE16	Retain		
oPE17	Motor Rated Speed Setting Error	1. Motor rated speed setting over the motor synchronous	1. Set the motor base frequency and the correct number of motor

Keypad Display	Error Name	Cause	Possible Solution
		speed	poles 2. Correctly set the motor rated speed Motor synchronous speed = $120 \times$ base frequency / motor pole number
oPE18	Retain		

6.4 Auto-Tuning Fault Detection

Table 6.4 Auto-Tuning Codes, Causes, and Possible Solution

Keypad Display	Fault Name	Cause	Possible Solution
TnF00	Auto-Tuning Stop	User presses STOP key during Auto-Tuning	Do not press STOP key during Auto-Tuning
TnF01	Line-to Line Resistance Error	The line-to-line resistance in Auto-Tuning is negative or limited by the upper the lower limit	Check and correct motor wiring
TnF02	Stationary Auto-Tuning Error	The voltage or current is too large during stationary Auto-Tuning	Make sure the data entered in t1-03 to t1-05 is the same as the information showed on the motor nameplate Check and correct motor wiring
TnF03	Rotational Auto-Tuning Error	The voltage or current is too large during rotational Auto-Tuning	Make sure the data entered in t1-03 to t1-05 is the same as the information showed on the motor nameplate Check and correct motor wiring Perform Auto-Tuning after disconnect the motor from the machinery
TnF07	Motor Data Error	t5-05 and t1-07 setting incorrect	Make sure the data entered to t1-05 and t1-07 is the same as the information showed on the motor nameplate. Reset the parameters.
TnF09	PM Motor Inductance Error	The voltage or current is too large or the inductance value is error during inductance Auto-Tuning	Make sure the parameter is properly set according to the motor nameplate. Reset T2 parameters
TnF10	PM Motor Back EMF Error	The voltage or current is too large or the value is error during back EMF Auto-Tuning	Make sure the parameter is properly set according to the motor nameplate. Reset T2 parameters

Chapter 7 | Communications

7.1 Modbus Communication Specifications

Item	Specifications
Interface	RS-485
Communications Cycle	Asynchronous
Communication Parameters	Communication speeds
	Data length
	Select even, odd or none
	Stop bit
Protocol	Modbus
Max number of Slaves	31 AC drives

7.2 Connecting to Controller/PLC/HMI

7.2.1 Communication Cable Connection

1. Connect the communications cable to the drive and the controller/PLC/HMI when the power is cut off. Use the drive terminal RJ45 for Modbus communication.

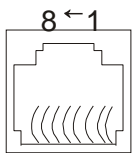

RS-485

Modbus RS-485

Pin 1~2, 7, 8: 保留

Pin 3, 6:SGND

Pin 4:SG-

Pin 5:SG+

Note: To prevent the interference, separate the communications cables from the main circuit cables, power cable and other wiring. Always use shielded cables for the communications cables, and shielded clamps.

2. Ensure the termination resistor is installed in the last drive of the slave series.
3. Turn the power on.
4. Set the parameters needed for the communication(E6 - 00 to E6 - 12) using the keypad.
5. Shut the power off and wait until the display goes out.
6. Turn the power on.
7. The communication between the drive and the controller/PLC/HMI is now ready.

7.3 Message Format

7.3.1 Slave Station Address

Use code between 0 and FF (hex) to set the slave station address. If a message with slave station address 0 is sent (broadcast), the command from the master will be sent to all slaves. The slave do not responds to a broadcast message.

00H: To all drive (broadcast)

01H: To drive address 01

0FH: To drive address 15

10H: To drive address 16, so on and so forth up to 31(1FH).

7.3.2 Function Code

There are four types of function codes:

03H : Read Modbus registers

06H : Write a word to registers(Write to registers)

08H : Loopback test

10H : Write to multiple registers

7.4 Modbus Data

The following tables shows all data including command, monitor and broadcast.

■ Command Data (Read and write)

Register No.	Definitions	
2400H	Retain	
2401H	Operation Commands	
	Bit 0	Stop/Run (0:Stop, 1:Run)
	Bit 1	Forward/Reverse (0:Forward, 1:Reverse)
	Bit 2	External Fault EF0
	Bit 3	Fault reset
	Bit 4	Retain
	Bit 5	Retain
	Bit 6	Retain
	Bit 7	Retain
	Bit 8	Multi-Function Terminal 1 (1: ON)
	Bit 9	Multi-Function Terminal 2 (1: ON)
	Bit 10	Multi-Function Terminal 3 (1: ON)
	Bit 11	Multi-Function Terminal 4 (1: ON)
	Bit 12	Multi-Function Terminal 5 (1: ON)
	Bit 13	Multi-Function Terminal 6 (1: ON)
	Bit 14	Multi-Function Terminal 7 (1: ON)
Bit 15	Retain	
2402H	Frequency Command (0.01Hz Units)	
2403H	Retain	

■ Monitor Data (Read Only)

Register No.	Definitions	
2420H	Retain	
2421H	Operation Status	
	Bit 0	1: During Run
	Bit 1	1: During reverse
	Bit 2	1: During Zero Speed Holding
	Bit 3	1: During fault
	Bit 4	1: During alarm detecton
Bit 5	1: During speed agree	

	Bit 6	1: During ready
	Bit 7	1: Frequency command provided from ?
	Bit 8	1: Run command provided from Remote
	Bit 9 to 15	Retain
2422H	Frequency command (0.01Hz units)	
2423H	Output frequency (0.01Hz units)	
2424H	Output current (0.1A units)	
2425H	Output voltage (0.1V units)	
2426H	DC voltage (0.1V units)	
2427H	Alarm description	
2428H	Fault description	
	Multi-Function Inputs and Outputs Status	
2429H	Bit 0	1: Multi-Function Terminal 1 ON
	Bit 1	1: Multi-Function Terminal 2 ON
	Bit 2	1: Multi-Function Terminal 3 ON
	Bit 3	1: Multi-Function Terminal 4 ON
	Bit 4	1: Multi-Function Terminal 5 ON
	Bit 5	1: Multi-Function Terminal 6 ON
	Bit 6	1: Multi-Function Terminal 7 ON
	Bit 7 to 11	Retain
	Bit 12	1: Relay 1 ON
	Bit 13	1: Relay 2 ON
	Bit 14	1: PH1 ON
	Bit 15	Retain
242AH	AI1 input (0 equals 0V or 0mA, 1000 equals 10V or 20mA)	
242BH	AI2 input (0 equals 0V or 4mA, 1000 equals 10V or 20mA)	
242CH	Retain	
242DH	AO1 input (-1000 equals -10V, 0 equals 0V or 4mA, 1000 equals 10V or 20mA)	
242EH	AO2 input (-1000 equals -10V, 0 equals 0V or 4mA, 1000 equals 10V or 20mA)	

■ Alarm Data (2427H)

No.	Contents	No.	Contents	No.	Contents
0	No alarm	13	保留	26	Ut1 (Undertorque Detection 1)
1	EF0 (Option Card	14	保留	27	Retain

	External Fault)				
2	EF1 (External Fault 1)	15	Retain	28	UL (Mechanical Weakening Undertorque Detection)
3	EF2 (External Fault 2)	16	Retain	29	OL (Mechanical Weakening Overtorque)
4	EF3 (External Fault 3)	17	Retain	30	Retain
5	EF4 (External Fault 4)	18	FbH (PID Feedback High)	31	BB (Output blocking)
6	EF5 (External Fault 5)	19	FbL (PID Feedback Low)	32	OH2 (Motor alarm)
7	EF6 (External Fault 6)	20	oH (Heatsink Overheat)	33	HCA (Overcurrent)
8	EF7 External Fault 7)	21	Retain	34	DNE (Invalid drive)
9	EF8 (External Fault 8)	22	ot1 (Overtorque Detection 1)	35	Retain
10	Retain	23	Retain	36	CE (MODBUS communication fail)
11	Retain	24	Ov (Overvoltage)	37	HPErr
12	Retain	25	Uv(Undervoltage)	38	ANL (Analog current input disconnection)
				48	UV2 (DC power relay abnormal slow start)

■ Fault Data (2428H)

No.	Contents	No.	Contents	No.	Contents
0	No fault	31	Retain	62	opr (LCM)
1	GF (Ground Fault)	32	Retain	63	SEr
2	oVA (Acceleration Overvoltage)	33	oH (Heatsink Overheat)	64	Retain
3	oVd (Deceleration Overvoltage)	34	Retain	65	CPF01
4	oVC (Constant Speed Overvoltage)	35	oL (Mechanical Weakening Overtorque Detection)	66	CPF02
5	oCA (Acceleration Overcurrent)	36	oL1 (Motor Overload)	67	CPF03
6	oCd (Deceleration	37	oL2 (Drive Overload)	68	CPF04

	Overcurrent)				
7	oCC (Constant Speed Overcurrent)	38	OL3	69	CPF05
8	EF	39	ot1 (Overtorque Detection 1)	70	CPF06
9	SC (IGBT Fault or Output Short Circuit)	40	Retain	71	CPF07
10	Retain	41	Ut1 (Undertorque Detection 1)	72	Retain
11	Retain	42	Retain	73	JOGER (FJOG, RJOG put in together)
12	Retain	43	UL (Mechanical Weakening Undertorque Detection)	74	-OFF-
13	Retain	44	Uv1(Undervoltage Detection 1)	75	Retain
14	Retain	45	Uv2 (Control Power Supply Voltage Fault)	76	ACE (Analog current output lines)
15	Retain	46	PF (Input Phase Loss)	77	Retain
16	Retain	47	LF1(Output Phase Loss)	78	Retain
17	EF0 (Option Card External Fault)	48	Retain	79	Retain
18	EF1 (External Fault 1)	49	Retain	80	Retain
19	EF2 (External Fault 2)	50	Retain	81	TNF00
20	EF3 (External Fault 3)	51	Retain	82	TNF01
21	EF4 (External Fault 4)	52	Retain	83	TNF02
22	EF5 (External Fault 5)	53	Retain	84	TNF03
23	EF6 (External Fault 6)	54	FbH (PID Feedback High)	85	TNF04
24	EF7 (External Fault 7)	55	FbL (PID Feedback Low)	86	TNF05
25	EF8 (External Fault 8)	56	bUS (Option Communication Error)	87	TNF06
26	Retain	57	CE (Modbus Communication Error)	88	TNF07
27	Retain	58	CF (Control Fault)	89	TNF08

28	Retain	59	Err (EEPROM Write Error)	90	TNF09
29	Retain	60	Retain	91	TNF10
30	Retain	61	Retain		

MODBUS code corresponding inverter parameters

parameter	code	parameter	code	parameter	code
A1-00	0x0000	A2-00	0x0080	A2-17	0x0091
A1-01	0x0001	A2-01	0x0081	A2-18	0x0092
A1-02	0x0002	A2-02	0x0082	A2-19	0x0093
A1-03	0x0003	A2-03	0x0083	A2-20	0x0094
A1-04	0x0004	A2-04	0x0084	A2-21	0x0095
A1-05	0x0005	A2-05	0x0085	A2-22	0x0096
A1-06	0x0006	A2-06	0x0086	A2-23	0x0097
		A2-07	0x0087	A2-24	0x0098
		A2-08	0x0088	A2-25	0x0099
		A2-09	0x0089	A2-26	0x009A
		A2-10	0x008A	A2-27	0x009B
		A2-11	0x008B	A2-28	0x009C
		A2-12	0x008C	A2-29	0x009D
		A2-13	0x008D	A2-30	0x009E
		A2-14	0x008E	A2-31	0x009F
		A2-15	0x008F	A2-32	0x00A0
		A2-16	0x0090		

parameter	code	parameter	code	parameter	code
B1-00	0x0100	B2-00	0x0180	B3-00	0x0200
B1-01	0x0101	B2-01	0x0181	B3-01	0x0201
B1-02	0x0102	B2-02	0x0182	B3-02	0x0202
B1-03	0x0103	B2-03	0x0183	B3-03	0x0203
B1-04	0x0104	B2-04	0x0184		
B1-05	0x0105			B4-00	0x0280
B1-06	0x0106			B4-01	0x0281
B1-07	0x0107				
B1-08	0x0108				
B1-09	0x0109				
B1-10	0x010A				
B1-11	0x010B				
B1-12	0x010C				

parameter	code	parameter	code	parameter	code
B5-00	0x0300	B5-21	0x0315	B6-00	0x0380
B5-01	0x0301	B5-22	0x0316	B6-01	0x0381
B5-02	0x0302	B5-23	0x0317	B6-02	0x0382
B5-03	0x0303	B5-24	0x0318	B6-03	0x0383
B5-04	0x0304	B5-25	0x0319		
B5-05	0x0305	B5-26	0x031A		
B5-06	0x0306	B5-27	0x031B		
B5-07	0x0307	B5-28	0x031C		
B5-08	0x0308	B5-29	0x031D		
B5-09	0x0309	B5-30	0x031E		
B5-10	0x030A				
B5-11	0x030B				
B5-12	0x030C				
B5-13	0x030D				
B5-14	0x030E				
B5-15	0x030F				
B5-16	0x0310				
B5-17	0x0311				
B5-18	0x0312				
B5-19	0x0313				
B5-20	0x0314				

parameter	code	parameter	code	parameter	code
C1-00	0x0580	C2-00	0x0600	C5-00	0x0780
C1-01	0x0581	C2-01	0x0601	C5-01	0x0781
C1-02	0x0582	C2-02	0x0602	C5-02	0x0782
C1-03	0x0583	C2-03	0x0603		
C1-04	0x0584				
C1-05	0x0585	C3-00	0x0680	C6-00	0x0800
C1-06	0x0586	C3-01	0x0681	C6-01	0x0801
C1-07	0x0587	C3-02	0x0682	C6-02	0x0802
C1-08	0x0588	C3-03	0x0683	C6-03	0x0803
C1-09	0x0589	C3-04	0x0684		
C1-10	0x058A	C3-05	0x0685	C7-00	0x2480
C1-11	0x058B	C3-06	0x0686		
C1-12	0x058C				

parameter	code	parameter	code	parameter	code
L1-00	0x0880	L1-13	0x088D	L4-00	0x0A00
L1-01	0x0881	L1-14	0x088E	L4-01	0x0A01
L1-02	0x0882	L1-15	0x088F	L4-02	0x0A02
L1-03	0x0883	L1-16	0x0890	L4-03	0x0A03
L1-04	0x0884			L4-04	0x0A04
L1-05	0x0885	L2-00	0x0900		
L1-06	0x0886	L2-01	0x0901	L6-00	0x0B00
L1-07	0x0887			L6-01	0x0B01
L1-08	0x0888	L3-00	0x0980	L6-02	0x0B02
L1-09	0x0889	L3-01	0x0981		
L1-10	0x088A	L3-02	0x0982		
L1-11	0x088B	L3-03	0x0983		
L1-12	0x088C				

parameter	code	parameter	code	parameter	code
L7-00	0x2380	L7-11	0x238B	L7-22	0x2396
L7-01	0x2381	L7-12	0x238C	L7-23	0x2397
L7-02	0x2382	L7-13	0x238D	L7-24	0x2398
L7-03	0x2383	L7-14	0x238E	L7-25	0x2399
L7-04	0x2384	L7-15	0x238F	L7-26	0x239A
L7-05	0x2385	L7-16	0x2390	L7-27	0x239B
L7-06	0x2386	L7-17	0x2391	L7-28	0x239C
L7-07	0x2387	L7-18	0x2392	L7-29	0x239D
L7-08	0x2388	L7-19	0x2393	L7-30	0x239E
L7-09	0x2389	L7-20	0x2394	L7-31	0x239F
L7-10	0x238A	L7-21	0x2395	L7-32	0x23A0
				L7-33	0x23A1

parameter	code	parameter	code	parameter	code
D1-00	0x0B80	D1-23	0x0B97	D2-00	0x0C00
D1-01	0x0B81	D1-24	0x0B98	D2-01	0x0C01
D1-02	0x0B82	D1-25	0x0B99	D2-02	0x0C02
D1-03	0x0B83	D1-26	0x0B9A	D2-03	0x0C03
D1-04	0x0B84	D1-27	0x0B9B	D2-04	0x0C04

D1-05	0x0B85	D1-28	0x0B9C	D2-05	0x0C05
D1-06	0x0B86			D2-06	0x0C06
D1-07	0x0B87			D2-07	0x0C07
D1-08	0x0B88			D2-10	0x0C0A
D1-09	0x0B89				
D1-10	0x0B8A				
D1-11	0x0B8B				

parameter	code	parameter	code	parameter	code
E1-00	0x0D00	E2-00	0x0D80	E3-00	0x0E00
E1-01	0x0D01	E2-01	0x0D81	E3-01	0x0E01
E1-02	0x0D02	E2-02	0x0D82	E3-02	0x0E02
E1-03	0x0D03	E2-03	0x0D83	E3-03	0x0E03
E1-04	0x0D04	E2-05	0x0D85	E3-05	0x0E05
E1-05	0x0D05	E2-06	0x0D86	E3-06	0x0E06
E1-06	0x0D06	E2-07	0x0D87	E3-07	0x0E07
E1-07	0x0D07	E2-08	0x0D88	E3-08	0x0E08
		E2-09	0x0D89	E3-09	0x0E09
				E3-10	0x0E0A
				E3-11	0x0E0B
				E3-12	0x0E0C

parameter	code	parameter	code	parameter	code
E4-00	0x0E80	E5-00	0x0F00	E6-00	0x0F80
E4-01	0x0E81	E5-01	0x0F01	E6-01	0x0F81
E4-02	0x0E82	E5-02	0x0F02	E6-02	0x0F82
E4-03	0x0E83	E5-03	0x0F03	E6-03	0x0F83
E4-04	0x0E84	E5-04	0x0F04	E6-04	0x0F84
E4-05	0x0E85	E5-05	0x0F05	E6-05	0x0F85
E4-06	0x0E86	E5-06	0x0F06	E6-06	0x0F86
E4-07	0x0E87	E5-07	0x0F07	E6-07	0x0F87
		E5-08	0x0F08	E6-08	0x0F88
		E5-09	0x0F09	E6-09	0x0F89
		E5-10	0x0F0A	E6-10	0x0F8A
				E6-11	0x0F8B
				E6-12	0x0F8C
				E6-13	0x0F8D

parameter	code	parameter	code	parameter	code
P1-00	0x1000	P2-00	0x1080	P3-00	0x1100
P1-01	0x1001	P2-01	0x1081	P3-01	0x1101
P1-03	0x1003	P2-03	0x1083	P3-02	0x1102
P1-04	0x1004	P2-04	0x1084	P3-03	0x1103
P1-05	0x1005	P2-05	0x1085	P3-04	0x1104
		P2-06	0x1086	P3-05	0x1105
		P2-07	0x1087	P3-06	0x1106
		P2-08	0x1088	P3-07	0x1107
		P2-09	0x1089	P3-08	0x1108
		P2-10	0x108A	P3-09	0x1109
		P2-11	0x108B	P3-10	0x110A
				P3-11	0x110B
				P3-12	0x110C
				P3-13	0x110D
				P3-14	0x110E
				P3-15	0x110F

parameter	code	parameter	code	parameter	code
P4-00	0x1180	P5-00	0x1200	P6-00	0x1280
P4-01	0x1181	P5-01	0x1201	P6-01	0x1281
P4-02	0x1182	P5-02	0x1202	P6-02	0x1282
P4-03	0x1183			P6-07	0x1287
P4-04	0x1184			P6-08	0x1288
P4-05	0x1185			P6-09	0x1289
P4-06	0x1186			P6-10	0x128A

parameter	code	parameter	code	parameter	code
P7-00	0x1300	N1-00	0x1380	N2-00	0x1400
P7-01	0x1301	N1-01	0x1381	N2-01	0x1401
P7-02	0x1302	N1-02	0x1382	N2-02	0x1402
P7-03	0x1303	N1-03	0x1383		
P7-04	0x1304				
P7-05	0x1305				
P7-06	0x1306				
P7-07	0x1307				
P7-09	0x1309				
P7-10	0x130A				
P7-11	0x130B				
P7-12	0x130C				
P7-13	0x130D				
P7-14	0x130E				

parameter	code	parameter	code	parameter	code
O1-00	0x1680	O2-00	0x1700	O3-00	0x1780
O1-01	0x1681	O2-01	0x1701	O3-01	0x1781
O1-02	0x1682	O2-03	0x1703	O4-00	0x1800
O1-03	0x1683	O2-04	0x1704	O4-01	0x1801
		O2-05	0x1705	O4-02	0x1802
		O2-06	0x1706	O4-06	0x1806
				O4-07	0x1807

parameter	code	parameter	code	parameter	code
T1-01	0x1881				
T1-02	0x1882				
T1-03	0x1883				
T1-04	0x1884				
T1-05	0x1885				
T1-06	0x1886				
T1-07	0x1887				
T1-09	0x1889				
T1-12	0x188C				

parameter	code	parameter	code	parameter	code
U1-00	0x1D00	U2-00	0x1D80	U3-00	0x1E00
U1-01	0x1D01	U2-01	0x1D81	U3-01	0x1E01
U1-02	0x1D02	U2-02	0x1D82	U3-06	0x1E06
U1-03	0x1D03	U2-03	0x1D83	U3-07	0x1E07
U1-04	0x1D04	U2-04	0x1D84	U3-08	0x1E08
U1-05	0x1D05	U2-05	0x1D85	U3-09	0x1E09
U1-06	0x1D06	U2-06	0x1D86	U3-10	0x1E0A
U1-07	0x1D07	U2-07	0x1D87	U3-11	0x1E0B
U1-09	0x1D09	U2-08	0x1D88	U3-12	0x1E0C
U1-10	0x1D0A	U2-09	0x1D89	U3-13	0x1E0D
U1-11	0x1D0B	U2-10	0x1D8A	U3-14	0x1E0E
U1-12	0x1D0C	U2-11	0x1D8B	U3-15	0x1E0F
U1-13	0x1D0D	U2-13	0x1D8D	U3-17	0x1E11
U1-14	0x1D0E	U2-14	0x1D8E	U3-18	0x1E12
U1-15	0x1D0F	U2-15	0x1D8F		
U1-16	0x1D10	U2-16	0x1D90	U4-00	0x1E80
		U2-17	0x1D91	U4-01	0x1E81
		U2-19	0x1D93	U4-02	0x1E82
		U2-20	0x1D94	U4-03	0x1E83
		U2-21	0x1D95	U4-04	0x1E84
		U2-22	0x1D96	U4-05	0x1E85
		U2-23	0x1D97	U4-06	0x1E86
		U2-24	0x1D98	U4-08	0x1E88
		U2-25	0x1D99		
		U2-27	0x1D9B		
		U2-28	0x1D9C		
		U2-29	0x1D9D		
		U2-30	0x1D9E		
		U2-31	0x1D9F		
		U2-33	0x1DA1		
		U2-34	0x1DA2		
		U2-35	0x1DA3		
		U2-36	0x1DA4		
		U2-37	0x1DA5		

Edit Date Parameter			Edit Date Parameter		
A1-00			b1-00		
A1-01			b1-01		
A1-02			b1-02		
A1-03			b1-03		
A1-04			b1-04		
A1-05			b1-05		
A1-06			b1-06		
A2-00			b1-07		
A2-01			b1-08		
A2-02			b1-09		
A2-03			b1-10		
A2-04			b2-00		
A2-05			b2-01		
A2-06			b2-02		
A2-07			b2-03		
A2-08			b2-04		
A2-09			b3-00		
A2-10			b3-01		
A2-11			b3-02		
A2-12			b3-03		
A2-13			b3-04		
A2-14			b3-05		
A2-15			b4-00		
A2-16			b4-01		
A2-17			b5-00		
A2-18			b5-01		
A2-19			b5-02		
A2-20			b5-03		
A2-21			b5-04		
A2-22			b5-05		
A2-23			b5-06		
A2-24			b5-07		
A2-25			b5-08		
A2-26			b5-09		
A2-27			b5-10		
A2-28			b5-11		
A2-29			b5-12		
A2-30			b5-13		
A2-31			b5-14		
A2-32			b5-15		

Edit Date Parameter			Edit Date Parameter		
b5-16			C4-01		
b5-17			C4-02		
b5-18			C4-03		
b5-19			C4-04		
b5-20			C4-05		
b5-21			C4-06		
b5-22			C4-07		
b5-23			C4-08		
b5-24			C4-09		
b5-25			C4-10		
b5-26			C4-11		
b5-27			C4-12		
b5-28			C4-13		
b6-00			C4-14		
b6-01			C4-15		
b6-02			C4-16		
b6-03			C4-17		
C1-00			C4-18		
C1-01			C4-19		
C1-02			C4-20		
C1-03			C4-21		
C1-04			C5-00		
C1-05			C5-01		
C1-06			C5-02		
C1-07			C5-03		
C1-08			C5-04		
C1-09			C5-05		
C1-10			C5-06		
C2-00			C5-07		
C2-01			C5-08		
C2-02			C5-09		
C2-03			C5-10		
C3-00			C6-00		
C3-01			C6-01		
C3-02			C6-02		
C3-03			C6-03		
C3-04			C6-04		
C3-05			L1-00		
C3-06			L1-01		
C4-00			L1-02		

Edit Date Parameter			Edit Date Parameter		
L1-03			d1-13		
L1-04			d1-14		
L1-05			d1-15		
L1-06			d1-16		
L1-07			d1-17		
L1-08			d1-18		
L1-09			d1-19		
L1-10			d1-20		
L1-11			d1-21		
L1-12			d1-22		
L1-13			d2-00		
L1-14			d2-01		
L1-15			d2-02		
L1-16			d2-03		
L2-00			d2-04		
L2-01			d2-05		
L3-00			d2-06		
L3-01			d2-07		
L3-02			d2-08		
L3-03			d2-09		
L4-00			d2-10		
L4-01			d2-11		
L4-02			d2-12		
L4-03			d2-13		
L6-00			d2-14		
L6-01			d2-15		
L6-02			d2-16		
d1-00			d2-17		
d1-01			d2-18		
d1-02			d2-19		
d1-03			d2-20		
d1-04			d2-21		
d1-05			d3-00		
d1-06			d3-01		
d1-07			d3-02		
d1-08			d3-03		
d1-09			d3-04		
d1-10			d3-05		
d1-11			d3-06		
d1-12			d3-07		

Edit Date Parameter			Edit Date Parameter		
d3-08			E5-03		
d3-09			E5-04		
E1-00			E5-05		
E1-01			E5-06		
E1-02			E5-07		
E1-03			E6-00		
E1-04			E6-01		
E1-05			E6-02		
E1-06			E6-03		
E1-07			E6-04		
E2-00			E6-05		
E2-01			E6-06		
E2-02			E6-07		
E2-03			E6-08		
E2-04			E6-09		
E2-05			E6-10		
E3-00			E6-11		
E3-01			P1-00		
E3-02			P1-01		
E3-03			P1-02		
E3-04			P1-03		
E3-05			P1-04		
E3-06			P1-05		
E3-07			P2-00		
E3-08			P2-01		
E3-09			P2-02		
E3-10			P2-03		
E3-11			P2-04		
E3-12			P2-05		
E4-00			P2-06		
E4-01			P2-07		
E4-02			P2-08		
E4-03			P2-09		
E4-04			P2-10		
E4-05			P3-00		
E4-06			P3-01		
E4-07			P3-02		
E5-00			P3-03		
E5-01			P3-04		
E5-02			P3-05		

Edit Date Parameter			Edit Date Parameter		
P3-06			P7-06		
P3-07			P7-07		
P3-08			P7-08		
P3-09			P7-09		
P3-10			P7-10		
P3-11			P7-11		
P3-12			P7-12		
P3-13			P7-13		
P3-14			n1-00		
P3-15			n1-01		
P3-16			n1-02		
P4-00			n1-03		
P4-01			n6-00		
P4-02			n6-01		
P4-03			n6-02		
P5-00			n6-03		
P5-01			n6-04		
P5-02			n6-05		
P6-00			n6-06		
P6-01			n6-07		
P6-02			n6-08		
P6-03			n6-09		
P6-04			n6-10		
P6-05			n6-11		
P6-06			n6-12		
P6-07			o2-00		
P6-08			o2-01		
P6-09			o2-02		
P6-10			o2-03		
P6-11			o2-04		
P6-12			o2-05		
P6-13			o2-06		
P6-14			o4-00		
P6-15			o4-01		
P7-00			o4-02		
P7-01			o4-03		
P7-02			o4-04		
P7-03			o4-05		
P7-04			o4-06		
P7-05			o4-07		

Edit Date Parameter			Edit Date Parameter		
o4-08			F1-10		
t1-00			F1-11		
t1-01			F1-12		
t1-02			F1-13		
t1-03			F1-14		
t1-04			F1-15		
t1-05			F1-16		
t1-06			F1-17		
t1-07			F1-18		
t1-08					
t1-09					
t1-10					
t1-11					
t1-12					
t2-00					
t2-02					
t2-03					
t2-04					
t2-05					
t2-06					
t2-07					
t2-08					
t2-09					
t2-10					
t2-11					
t2-12					
t2-13					
t2-14					
t2-15					
t2-16					
t2-17					
F1-00					
F1-01					
F1-02					
F1-03					
F1-04					
F1-06					
F1-07					
F1-08					
F1-09					

EVOLution Series

LITEON Industrial Automation

Lite-On Group Headquarters

22F, 392, Ruey Kuang Road, Neihu, Taipei City 114, Taiwan

Lite-On IA Headquarters

11F, 866-1, Chung-Zheng Rd., Chung Ho District, New Taipei City 235, Taiwan

Factory

7, Lane 3, San-Ho Rd., San-Shi Village, Dayuan Town, Taoyuan County 337, Taiwan

Email: IA.Hotline.overseas@liteon.com

